



Address: str. Teatralnaya 2 / 202A,  
Dnipro, UKRAINE  
Website: [www.Overlock.com.ua](http://www.Overlock.com.ua)  
Phone: 0800 210 034  
Mail: [brother1034@ukr.net](mailto:brother1034@ukr.net)

  
**ricoma**  
THINK BEYOND

# EM-1010

Home embroidery machine  
Operations manual





© 2016 Ricoma® All rights reserved.

Ricoma® and Ricoma® logo are registered trademarks of Ricoma® (SHENZHEN) CO., LTD. Products mentioned herein are for identification purposes only and may be registered trademarks or trademarks of their respective companies. All other brand names, trademarks or registered trademarks are the property of their respective owners.

---

# CONTENTS

Introduction .....	8
Intel® license agreement .....	9
Compliance & wattage.....	9
Customer service & support & training .....	10
 Read all instructions prior to operating .....	11
 Important safeguards and warnings .....	12
Tool box & spare parts.....	15
Embroidery machine assembly.....	16
Embroidery machine stand assembly (optional) .....	16
Thread rack assembly .....	19
Thread stand assembly .....	20
Unpacking your embroidery machine.....	23
Adjust & secure your embroidery machine .....	24
Embroidery machine & embroidery hoops overview.....	25
Front view .....	25
Rear view.....	26
Flat frame support .....	27
Embroidery hoop specifications .....	28
Touch screen.....	29
Bobbin overview .....	31
Placing the bobbin into the bobbin case .....	32
Placing the bobbin case into the rotary hook.....	33
Bobbin removal.....	34
Bobbin fiber choices.....	35
Cotton .....	35
Nylon .....	35
Continuous filament polyester .....	35
Spun polyester .....	36
Magna glide.....	36
Thread overview .....	37
Threading the embroidery machine/top threading.....	37

Threading a needle .....	42
Changing the spool .....	43
Knot tying.....	44
Trimming.....	44
Thread fiber choices.....	45
Rayon thread.....	45
Polyester thread.....	45
Metallic thread.....	46
Cotton thread.....	46
Thread consumption.....	46
Backing.....	47
Cut-away .....	47
Tear-away.....	48
Specialty backing.....	48
Topping .....	48
Foam .....	48
Poly mesh backing.....	49
Fusible backing.....	49
Backing & needle recommendations .....	50
Canvas .....	50
Canton fleece .....	50
Coated or waterproof .....	50
Corduroy .....	50
Cotton sheeting.....	50
Denim.....	50
Dress shirt (woven) .....	50
Golf shirt .....	50
Headwear .....	50
Leather and vinyl.....	50
Lingerie or silk .....	51
Lycra or spandex .....	51
Nylon windbreaker.....	51
Satin jacket.....	51

Sweater knit .....	51
Sweatshirt .....	51
T-shirt .....	51
Terry cloth .....	51
Before getting started .....	52
Getting started .....	53
Turning on .....	53
Turning off .....	53
Control panel overview .....	54
Home page .....	55
Logo selection page .....	57
Color sequence page .....	57
Design setting page .....	58
Comprehensive menu settings page .....	59
Control panel functions .....	60
Start/Stop .....	60
To start .....	60
To stop .....	60
Importing/uploading a design .....	61
Selecting a design .....	62
Selecting an embroidery hoop .....	62
Selecting the color sequence .....	63
Color change mode .....	64
Needle switch display icon .....	64
Embroidery design trace .....	65
Using float mode .....	65
Frame out .....	66
Low speed .....	67
Trimming .....	67
Embroidery status .....	68
Tracing the embroidery area .....	68
Deleting a design .....	69
Adding a font .....	69

How to abort a job .....	70
How to adjust speed .....	70
How to bring the frame out .....	71
Embroidery hoop & flat frame support .....	72
Flat frame support installation .....	73
Installing embroidery hoop & adjusting flat frame support .....	74
Framing fabric .....	75
Removing the embroidery hoop .....	77
Removing the flat frame support .....	77
Caps overview .....	78
Cap driver installation .....	78
Cap station installation .....	79
Cap embroidery hoop .....	79
Cap installation .....	80
Cap embroidery hoop removal .....	80
Cap driver removal .....	80
Tension .....	81
Check thread tension .....	81
Tension knobs .....	82
Adjusting thread tension .....	82
Bobbin tension .....	83
Needles .....	84
Anatomy of a needle .....	84
Needle lifetime .....	84
When to change a needle .....	84
Selecting a needle .....	85
Blade size .....	85
Needle finishes .....	86
Needle & thread matrix .....	86
Point types .....	87
Acute round point .....	87
Slender sharp point .....	87
Normal sharp point .....	87

Light ballpoint .....	87
Medium ballpoint.....	87
Needle replacement .....	88
Completing a flat design (start to finish) .....	89
Prepare.....	89
Embroider .....	89
Completing a caps design (start to finish).....	90
Prepare.....	90
Embroider .....	90
Maintenance & care.....	91
Rotary hook.....	91
Machine head .....	91
Level arms .....	91
Head rail.....	92
Bobbin case maintenance .....	92
Troubleshooting.....	93
Thread break.....	93
Reasons .....	93
Prevention.....	94
Needle break.....	94
Bobbin tension .....	94
Timing overview.....	95
Adjusting the timing of a needle and hook.....	95
Error messages.....	96
Thread break (“T-break”).....	96
Needle break.....	96
Main axis not at 100 degrees .....	97
Quick reference guide/checklist .....	98

---

# INTRODUCTION

## Customer satisfaction

Thank you for purchasing the 10-needle home embroidery machine with the 7-inch HD LCD touch-screen panel. We appreciate your business, value your feedback, and want to ensure your experience with us is a memorable one – every time. Our customer satisfaction team is ready to help you with every question you might have and provide you with the best service you deserve as our valued customer.



*THINK BEYOND*

## Quality products

Our engineers are constantly using the latest technologies and innovative ideas to improve and set new standards in our industry. We handcraft our products at our state-of-the-art manufacturing plant. Our professional staff operates efficiently to develop the best designs and durable embroidery machines with integrated software applications. With the established strict and comprehensive quality inspections that start by the purchasing of raw materials, followed by the assembly and finished products, and ends with the packaging and shipping from our home office in Miami, Florida. With these quality standards, Ricoma is proud of and recognized for its quality products.

## Commitment to service

Our customers are the core of our business, and you are our #1 priority when it comes to providing the most comprehensive one-on-one and onsite training, customer service, latest software upgrades and replacement supplies. We are here to help you grow your business and establish a long-term relationship with you.





---

# INTEL® LICENSE AGREEMENT

For open source computer vision library



**IMPORTANT: READ BEFORE DOWNLOADING, COPYING, INSTALLING OR USING.**

By downloading, copying, installing or using the software, you agree to this license. If you do not agree to this license, do not download, install, copy or use the software.

## Intel® license agreement for open source computer vision library

Copyright © 2000, Intel Corporation, all rights reserved. Third party copyrights are the property of their respective owners.

**Redistribution and use in source and binary forms, with or without modification, are permitted if the following conditions are met:**

- Redistribution of source code must retain the above copyright notice, this list of conditions and the following disclaimer.
- Redistribution in binary form must reproduce the above copyright notice, this list of conditions and the following disclaimer in the documentation and/or other materials provided with the distribution.
- The name of Intel® Corporation may not be used to endorse or promote products derived from this software without specific prior written permission.
- This software is provided by the copyright holders and contributors “as-is” and any express or implied warranties, including, but not limited to, the implied warranties of merchantability and fitness for a particular purpose are disclaimed.
- In no event shall Intel® or contributors be liable for any direct, indirect, incidental, special, exemplary, or consequential damages (including, but not limited to, procurement of substitute goods or services; loss of use, data, or profits; or business interruption) however caused and on any theory of liability, whether in contract, strict liability, or tort (including negligence or otherwise) arising in any way out of the use of this software, even if advised of the possibility of such damage.
- All information provided related to future Intel® products and plans is preliminary and subject to change at any time, without notice.

---

## COMPLIANCE + WATTAGE



ISO Compliant

110V/60Hz or 220V/50Hz available

---

# CUSTOMER SERVICE + SUPPORT + TRAINING

At Ricoma®, we are dedicated to providing the best customer service, support and training. Our trained and certified technical staff is ready to help you. Whether you are a beginner or veteran embroiderer, our professional instructors have years of experience in the industry and can help you understand and operate your embroidery machine at your own pace and schedule.

If you should have any questions regarding your embroidery machine or training, please contact your local Ricoma® dealer to schedule an appointment.

**Please contact your local Ricoma® dealer first.**  
**To locate your local dealer, contact customer service.**

For customers located in **North America, Central America, South America and the Caribbean**, please visit Ricoma.us.

Our customer service & training department is located at the home office in Miami, FL (U.S.A.).

- Telephone: 305-418-4421 (Monday through Friday; 9 a.m. to 5:30 p.m. EST)
- Toll-free number: 1-888-292-6282 (Monday through Friday; 9 a.m. to 5:30 p.m. EST)
- Email: [service@ricoma.us](mailto:service@ricoma.us)
- Fax: 305-418-5036 or 305-418-4463

For customers located in **Asia, Europe, Africa, the Middle East and Oceania**, please contact your local distributor first or visit Ricoma.cn.

Our customer service department is located in Shenzhen, China.

- Telephone: +86-755-2585 7772 (Monday through Friday, 8 a.m. to 5:30 p.m., China time)
- Email: [service@ricoma.cn](mailto:service@ricoma.cn)
- Fax: +86-755-2585 7773

---

## READ ALL INSTRUCTIONS PRIOR TO OPERATING

- This manual is a comprehensive step-by-step user instruction guide on how to use the 10-needle home embroidery machine with the 7-inch HD LCD touch-screen panel.
- Make sure to read, understand and follow all these instructions.
- To address any questions relating to ordering parts, operating the 10-needle home embroidery machine with the 7-inch HD LCD touch-screen panel, troubleshooting, maintenance or service, please contact your local dealer.



## SAVE THESE INSTRUCTIONS

This embroidery machine is for indoor household use only.



# ⚠ IMPORTANT SAFEGUARDS AND WARNINGS

When using embroidery machines, the following safety precautions **MUST** be followed to reduce the risk of fire, electric shock, and/or injury.

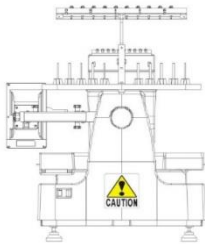

- The embroidery machine is provided with the following warning label: 
  - Exercise the important safeguards and warnings associated with the label.
  - **Improper use of this embroidery machine may result in temporary, permanent or fatal injuries.**
  - To prevent injuries, keep hands, body parts and other objects away from needle bar rack, guide rail, etc.
  - Keep the machine away from heat sources.
- 
- This embroidery machine is only for indoor household use. Do **NOT** use outdoors.
  - Do **NOT** use embroidery machine for other than its intended use.
  - This embroidery machine is **NOT** intended to be used by persons (including children) with reduced physical, sensory, or mental capabilities, or lack of experience and knowledge unless they are supervised while using the embroidery machine and given instruction on how to use the embroidery machine by the person responsible for their safety. The person who is giving instruction **MUST** have read and understand how to use this embroidery machine and assumes total responsibility for the safety of the person they are supervising.
  - **Children must NOT use this embroidery machine.**
  - Children should be supervised to ensure that they do **NOT** play with packing materials, plastic bags and/or the embroidery machine.
  - Close supervision is necessary when the embroidery machine is used near children.
  - To protect against electrical shock, do **NOT** immerse cord plug or embroidery machine in water or other liquids.
  - Turn off and unplug the embroidery machine from the electrical outlet when **NOT** in use and before cleaning. To unplug the embroidery machine, grab the power plug and pull it outwards from the electrical outlet. Do **NOT** pull the power cord.
  - Make sure the embroidery machine is turned off before inserting and/or removing parts.
  - It is recommended to regularly inspect the embroidery machine. Do **NOT** operate the embroidery machine with a damaged cord, plug, needles, bobbins, etc., or after the embroidery machine malfunctions or has been damaged in any manner.
  - Do **NOT** use accessory attachments that are **NOT** recommended by the embroidery machine manufacturer, since it may cause injuries and malfunctions of the embroidery machine.
  - Do **NOT** touch needles or sharp embroidery machine parts when installing or removing embroidery frames, accessory fittings or while providing maintenance to the embroidery machine.
  - Do **NOT** over extend power cord or let it touch hot surfaces.
  - Do **NOT** place embroidery machine on or near hot gas, an electric burner, an oven, a gas or electric cooktop, an open flame, an iron, or steam embroidery machine.
  - To turn off the embroidery machine press the "Stop" button, turn off the power switch at the rear of the embroidery machine and then unplug the power cord from electrical outlet. See the [Turning off section](#) for more information.
  - When using the embroidery machine, provide adequate air space above and around the sides of the machine for circulation. Do not block any ventilation opening while the embroidery machine is being used and make sure the ventilation opening is free from the accumulation fluff, dust and **NOT** covered by a cloth.
  - For extra protection, when operating the embroidery machine, use safety glasses and closed toe shoes to prevent injuries.
  - To replace the needles, use tweezers or pliers to grab the needle. Do **NOT** use your fingers.
  - Do **NOT** leave the embroidery machine unattended while in use, and press "Stop" in the case of an emergency. See the [Turning off section](#) for more information.

## IMPORTANT SAFEGUARDS AND WARNINGS (cont'd)

- The embroidery machine weighs about 95 pounds and should be carried between two people. Only lift the embroidery machine from its base and use caution to prevent back, knees and/or other types of injuries or damage to the embroidery machine.
- Do **NOT** lift or grab embroidery machine by the touch-screen or any of the removable parts.
- The embroidery machine's power cord **MUST** be plugged into a UPS power supply to protect it from a power surge, power outage and to provide enough time for embroidery job to be completed in case of a power outage.
- If there is a power outage and the embroidery machine is **NOT** plugged into a UPS power supply, it will turn off. If it is plugged into a UPS power supply, once the job is completed, turn off the embroidery machine and unplug it from the UPS power supply.
- If there is a power outage, turn off the embroidery machine and unplug it from the electrical outlet.
- Do **NOT** operate the embroidery machine if it is covered by or touching flammable materials, including towels, curtains, draperies, walls or anything similar.
- Do **NOT** store any flammable liquids near the embroidery machine.
- Do **NOT** operate the embroidery machine in a place where sprays are used or oxygen is stored.
- Do not store the embroidery machine in a place with direct sunshine or high humidity. Do not use or store the embroidery machine close to a heater, iron, halogen lamp or another high-temperature object.
- Do **NOT** place any item on top of the embroidery machine while in operation.
- Do **NOT** store any materials or items other than the manufacturer's recommended accessories on top or beneath the embroidery machine when **NOT** in use.
- Do **NOT** use any materials that are not recommended for the embroidery machine such as paper, cardboard, plastic, foam and other such materials or their likes.
- Use extreme caution **MUST** be used when moving the embroidery machine to prevent any injuries. It is recommended that the embroidery machine **NOT** be moved while it is being used or plugged into the electrical outlet.
- To prevent needle breakage, do not use damaged needles or an incorrect needle plate.
- Keep foreign objects away from embroidery machine openings to avoid personal injuries.
- When using scissors or seam rippers, keep hands and fingers away from the cutting direction to avoid injuries and only use them for their specified purpose.
- Do **NOT** use the embroidery machine on an unstable surface. Place the embroidery machine on a stable, leveled, and durable surface or use the EM-1010 embroidery machine stand.
- Do **NOT** use the EM-1010 embroidery machine stand to store anything else but the embroidery machine and its accessories.
- If the embroidery machine falls to the floor, it has been splashed with or soaked in water or other liquids do **NOT** use it – contact your local dealer to schedule an appointment with a qualified technician to service the embroidery machine. **Contact** your local Ricoma® dealer.
- Do **NOT** use the embroidery machine if it begins to heat up, color changes or deformation occurs, stop using the embroidery machine immediately, turn it off, and unplug it from the electrical outlet. Then **contact** your local Ricoma® dealer.
- Never wear loose articles of clothing that can be caught by the needles or any part of the embroidery machine while it is being used.
- The end user **MUST** never attempt to repair or modify the embroidery machine in any way and **MUST** **contact** their local Ricoma® dealer or **customer service at 1-888-292-6282** to schedule repairs with a factory certified technician. Working on the Ricoma® embroidery machine by the end user may result in voiding of the warranty.
- Ricoma®, its owners, partners, officers, employees, affiliates, manufacturers, factories, importers, promoters, parent companies and anyone else who does business with them are **NOT** responsible or liable for anyone



misusing the EM-1010 embroidery machine, modifying the original embroidery machine in anyway, servicing it with unauthorized personnel, not following or ignoring instructions, or using the embroidery machine for anything else other than its intended use.

- **Three-prong plug:** The EM-1010 embroidery machine has a 3-prong plug. To reduce the risk of electric shock, this plug is intended to fit into the outlet only one way. If the plug does not fully fit into the outlet, contact a qualified electrician. Do not attempt to modify the plug in any way. Do **NOT** use an extension cord with this embroidery machine.
- **Tamper-resistant screw:** This appliance is equipped with a tamper-resistant screw to prevent removal of the outer cover. To reduce the risk of fire or electric shock, **DO NOT** attempt to remove the outer cover. There are no user-serviceable parts inside. Authorized service personnel should **ONLY** do the repair.
- **Power cord:** To prevent damage, electric shock or fire hazard, do **NOT** operate the embroidery machine with a damaged power cord or if power plug is not completely inserted into the electrical outlet. If the power cord is damaged, please **contact** your local Ricoma® dealer or **customer service at 1-888-292-6282**.

# TOOL BOX + SPARE PARTS

Check List		
	Description	Quantity
<input type="checkbox"/>	Cushion	5
<input type="checkbox"/>	Needle clamp	2
<input type="checkbox"/>	Needle bar spring-DT	3
<input type="checkbox"/>	Position block spring	1
<input type="checkbox"/>	Press foot spring-DT	3
<input type="checkbox"/>	Press foot-EM	2
<input type="checkbox"/>	Take-up lever positioning block	2
<input type="checkbox"/>	Take-up lever set	2
<input type="checkbox"/>	Needle-DBxK5 75/11	10
<input type="checkbox"/>	USB-4G	1
<input type="checkbox"/>	Brush	1
<input type="checkbox"/>	M4X12 sank cross head screw	5
<input type="checkbox"/>	Needle clamp screw	3
<input type="checkbox"/>	Round head screw 4 by 8	10
<input type="checkbox"/>	Round head screw 4 by 12	3
<input type="checkbox"/>	Scissors	1
<input type="checkbox"/>	Rotate cap flat screw driver TU101-1.5 mm	1
<input type="checkbox"/>	Adjustable screw driver 4 by 107 mm	1
<input type="checkbox"/>	Adjustable screw driver 6 by 173 mm	1
<input type="checkbox"/>	Screw driver – z shape	1
<input type="checkbox"/>	7 Shape wrench – 6 set inches	1
<input type="checkbox"/>	Pliers – 5"/125 mm	1
<input type="checkbox"/>	Oil can – 40 grams	1
<input type="checkbox"/>	Needle bar – DT [210]	2
<input type="checkbox"/>	Thread post	2
<input type="checkbox"/>	Thread disc pad	2
<input type="checkbox"/>	Thread disc sponge pad	2
<input type="checkbox"/>	Threading pipe set-270	2
<input type="checkbox"/>	Threading steel – $\varnothing$ 1.4 mm by 400 mm	1
<input type="checkbox"/>	Spare parts box-D type	1
<input type="checkbox"/>	Multi-functional open wrench	1

# EMBROIDERY MACHINE ASSEMBLY



- Design patterns will embroider incorrectly if the embroidery machine is not set up properly.

## Embroidery machine stand assembly [optional]

### Tools & Parts:

- 8 screws
- 8 washers
- 8 lock washers
- 8 hex head nuts
- 2 Allen wrenches
- 4 casters
- 4 level pegs
- 2 table legs
- 2 connection plates
- 1 table

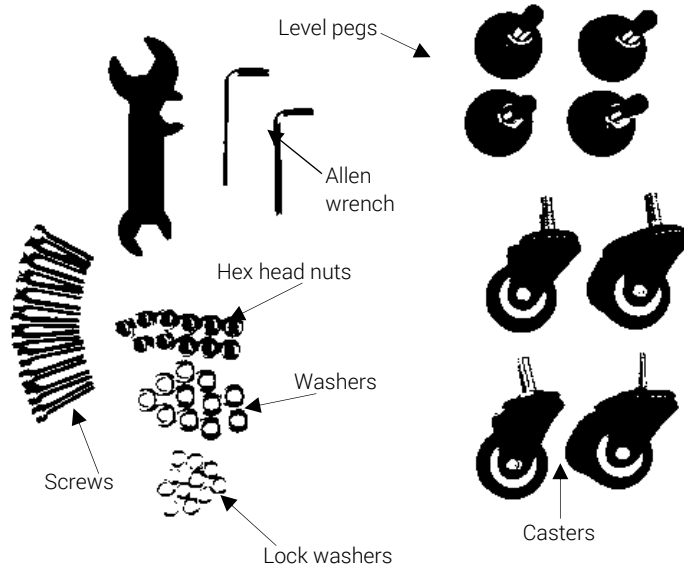

Figure 1

MODEL: ST-10

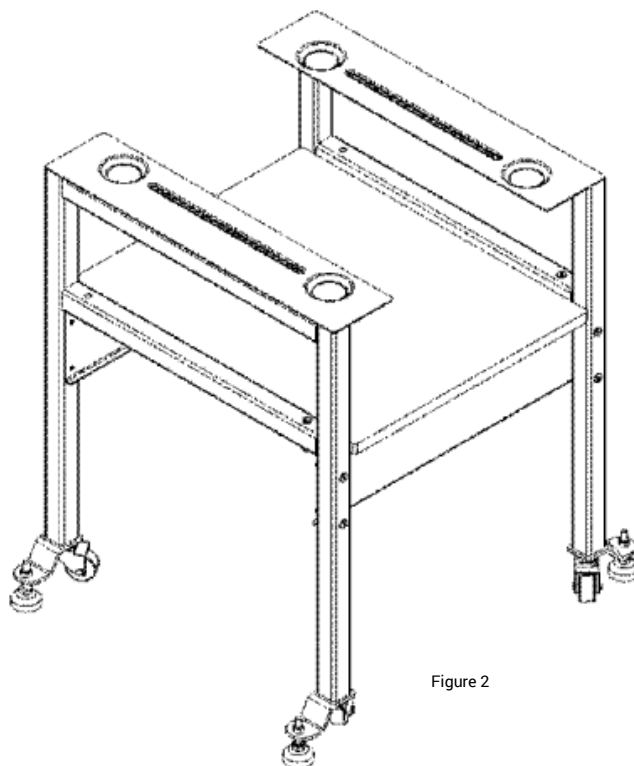

Figure 2



1. Lay each table leg, as shown in Figure 3, on a flat surface.

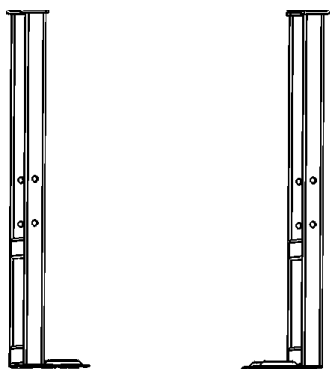

Figure 3

2. Take a connecting plate and begin by attaching it to one of the legs.

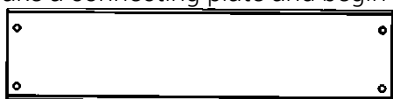

Figure 4

3. Take a screw from the toolkit.
4. Place a lock washer over the screw and then a washer. See Figure 6 for more details.

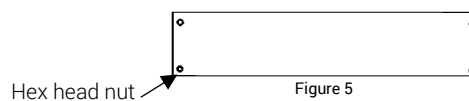

Figure 5

5. Locate one (1) of the twelve (12) screw holes on the connecting plate.
6. Insert the hex head nut on the outer side of the screw hole and insert the screw through the inner side of the screw hole, as shown in Figure 6.

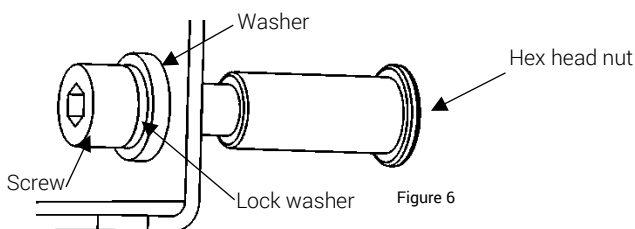
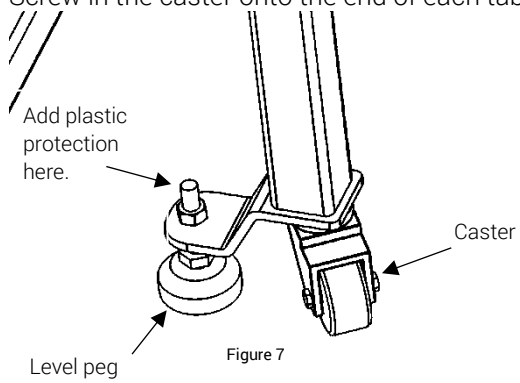

Figure 6

7. Repeat steps three (3) through five (5) on the remaining eleven (11) screw holes.
8. Once you have attached all twelve (12) screws, use an Allen wrench to tighten all twelve (12) of the screws.
  - a. Insert one Allen wrench into the screw end and hold the Allen wrench steady.
  - b. At the same time, insert the second Allen wrench into the hex head nut end and begin to turn the Allen wrench clockwise.
9. Repeat step eight (8) for the remaining eleven (11) screws.



10. Screw in the caster onto the end of each table leg. See Figure 7.



11. Attach the level peg and add the plastic protection to the protruding screw piece onto all four legs.

See Figure 7.

12. Turn the stand around and place the table on top of the connecting plates. See Figure 8.

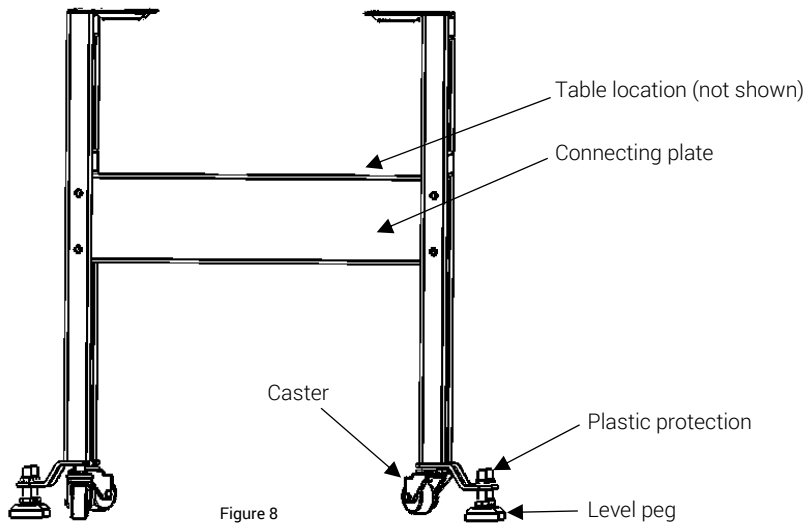

# Thread rack assembly

## Tools & Parts:

- 2 thread rack plates (TRP)
- 8 4 by 8 screws
- 1 reinforcing plate

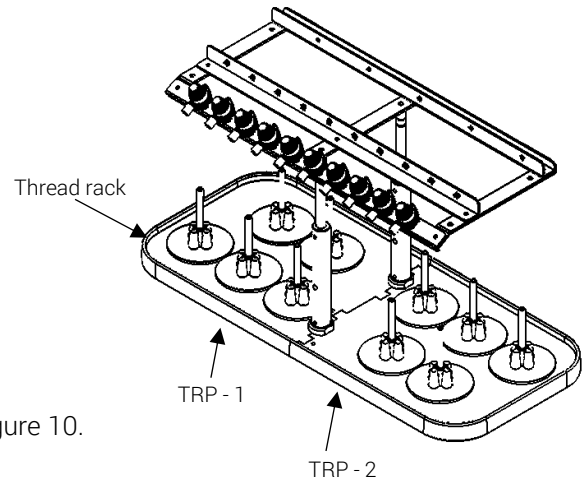

Figure 9

1. Take TRP-1 and TRP-2 and bring them together. See Figure 10.

- No. 1 – Thread rack plates

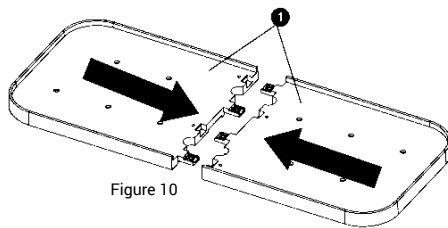

Figure 10

2. Ensure that the tongues and grooves of each TRP meet and the plates connect. Then, add screws to hold the TRPs together. See Figure 11.

- No. 1 – Screw locations

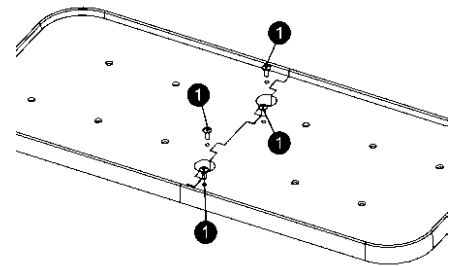

Figure 11

3. Place the reinforcement plates onto their location on the thread rack plates. See Figure 12.

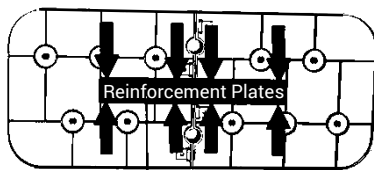

Figure 12

4. Screw the reinforcement plate to the back of the already-connected TRPs. See Figure 13.

- No. 1 – Screw locations
- No. 2 – Reinforcement plate
- No. 3 – Thread rack plates

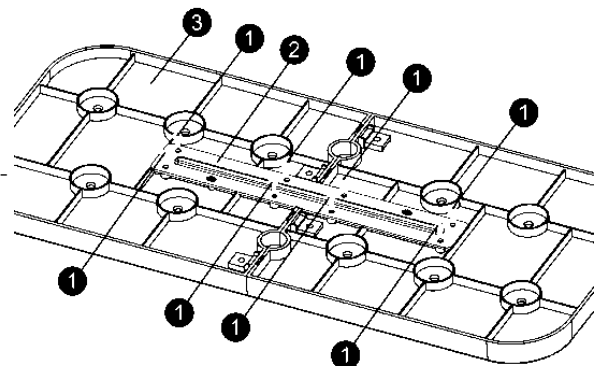

Figure 13

# Thread stand assembly

## Tools & Parts:

- 1 – 2.5 mm Allen wrench
- 10 thread pins
- 10 cushions
- 10 plastic thread reels

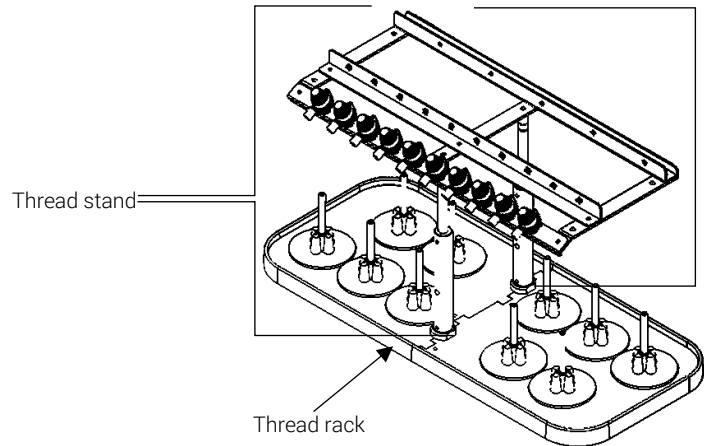

Figure 14

1. Locate the screws on the lock nuts at the bottom of the thread stand columns.
2. Loosen the screws on the lock nuts at the bottom of the thread stand columns.
3. Lift and remove the thread stand, then set it aside.
4. Remove the lock nuts from the thread stand columns. See Figure 15.

- No. 1 – Screws
- No. 2 – Lock nut

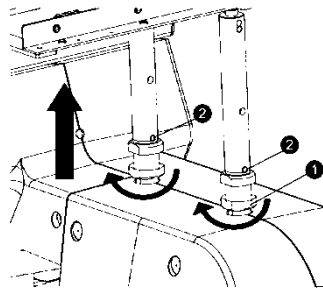

Figure 15

5. Reposition the thread stand onto the thread rack.
  - If you need instructions on how to assemble the thread rack, see the [Thread rack assembly](#) section.
6. Turn the thread rack around, add the lock nuts previously removed, and tighten them. See Figure 16.

- No. 1 – Thread stand column
- No. 2 – Thread rack
- No. 3 – Lock nut location

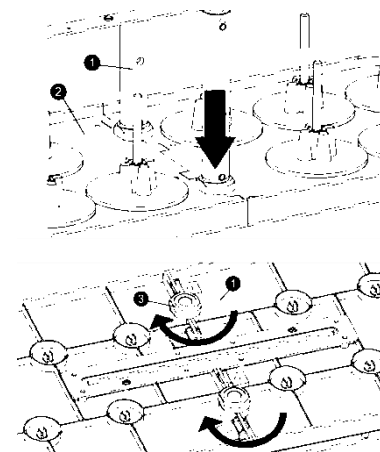

Figure 16

7. Reposition the thread rack onto the embroidery machine.
8. Tighten the two (2) long, top, hex heads to secure the thread stand onto the thread rack, as shown in Figure 17.

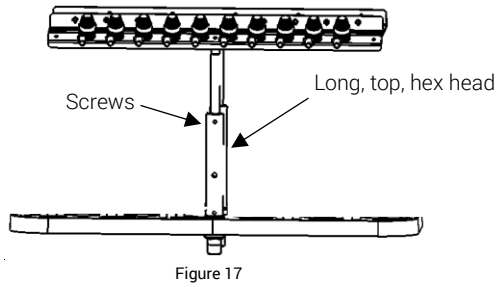

Figure 17

9. Ensure the thread stand has been securely attached.
10. Tighten the screws at the bottom of the two (2) thread stand columns with the allen wrench. See Figure 17.
11. Loosen the top screws.
12. Raise the thread stand up as high as possible.
13. Retighten the top screws.
14. Connect all ten (10) thread pins to the thread rack stand. See Figure 18.

- No. 1 – Thread rack
- No. 2 – Thread pin

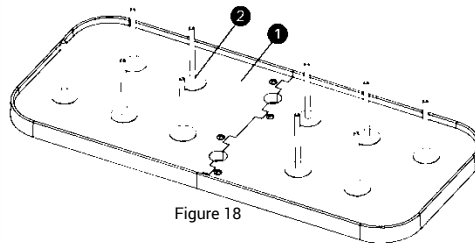

Figure 18

15. Place the sponge cushions on top of all ten thread pins, then push them through to the end. See Figure 19.

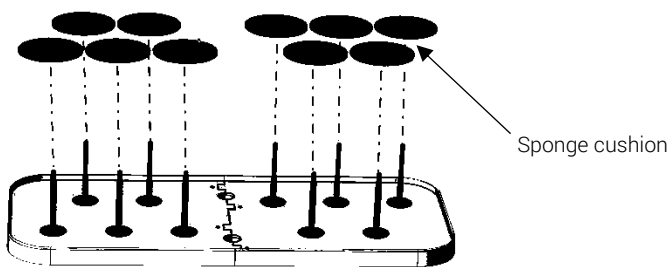

Figure 19

- If needed, place the plastic thread reel on top of the sponge cushions.
  - The plastic thread reels are used when the thread spool size in use is too large.

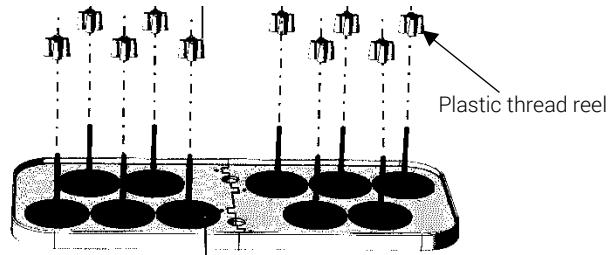

Figure 20

16. Choose a thread spool.

17. Remove the plastic cover.

- To remove plastic, grasp the plastic firmly, then slightly twist and pull.

18. Add the thread spool to the desired spool.

19. Repeat thread steps 16, 17 and 18, until all ten (10) thread spools are on the thread rack.

10 thread spool base	
Correct thread spool order	
• Spool pin #1	• Spool pin #7
• Spool pin #2	• Spool pin #6
• Spool pin #3	• Spool pin #8
• Spool pin #4	• Spool pin #9
• Spool pin #5	• Spool pin #10

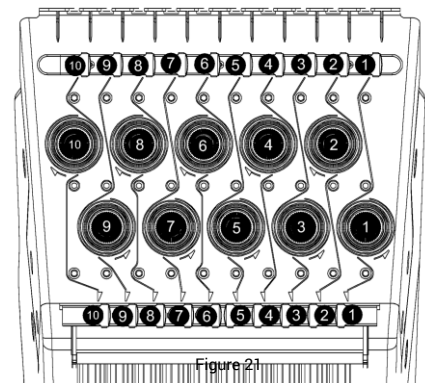

Figure 21

20. Remove the thread knot found on all ten (10) thread spools and allow the threads to hang.

21. See the [Threading the embroidery machine/top threading](#) section for instructions on how to thread your machine.

This section intentionally left blank.

# Unpacking your embroidery machine



- It is recommended to keep all shipping materials.
- Practice safety by using two (2) people to carry the embroidery machine.



1. Carefully remove the box by pulling upwards, using the cutouts found on the sides of the box.
2. Identify all of the accessories encased within the exterior of the styrofoam surrounding the embroidery machine.
3. Remove the accessories.
  - Cap driver
  - Thread stand
  - Flat attachment
  - Toolbox
  - Ethernet cable
  - Cap station
  - Thread cone holders
  - Embroidery hoops
  - Connecting cable
  - Power cord
4. Remove the styrofoam.
5. Remove the Velcro tie from the plastic bag covering the embroidery machine.
6. Pull the plastic cover down.
7. Lift the embroidery machine from the bottom and place it on top of the stand. ⚠ Use caution.
8. Align the embroidery base feet with the rivets found on top of the embroidery machine stand. See Figure 22.

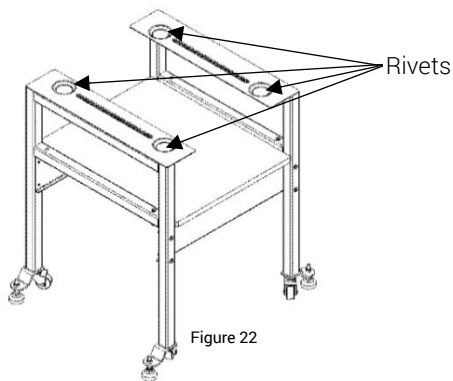

9. Remove the protection film.



## Adjust + secure your embroidery machine



- To avoid accidents or injuries, lift the embroidery machine between two (2) people.
- Keep the embroidery machine two inches (50 mm) away from the wall.
- Do not block the embroidery machine's ventilation.

1. Set up the embroidery machine on top of a leveled, balanced, and durable surface, or on top of the EM-1010 embroidery machine stand (model# ST-10). Make sure to remove all packaging materials from the embroidery machine.
2. Adjust the height of the base feet by rotating the adjusting nuts clockwise or counter clockwise. Once desired height has been achieved, lock the base feet by tightening the lock nut.

▲ Ensure all four (4) base feet have the same height.

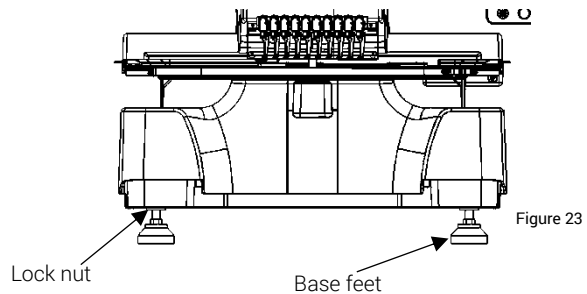

3. Adjust the length of the color LCD touch-screen panel by loosening the panel arm adjusting knobs. See Figure 24.

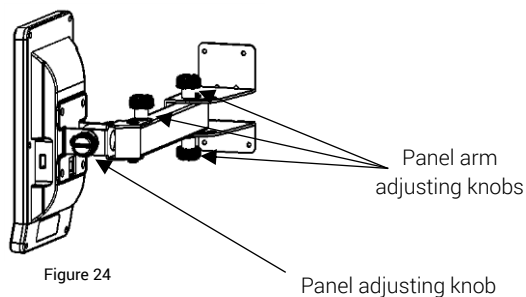

4. Tilt the color LCD touch-screen panel by loosening the panel adjusting knob, then tighten it again to hold the panel in place. See Figure 24.





# EMBROIDERY MACHINE + HOOPS OVERVIEW



Embroidery machine may vary slightly from what is illustrated.

## Front view

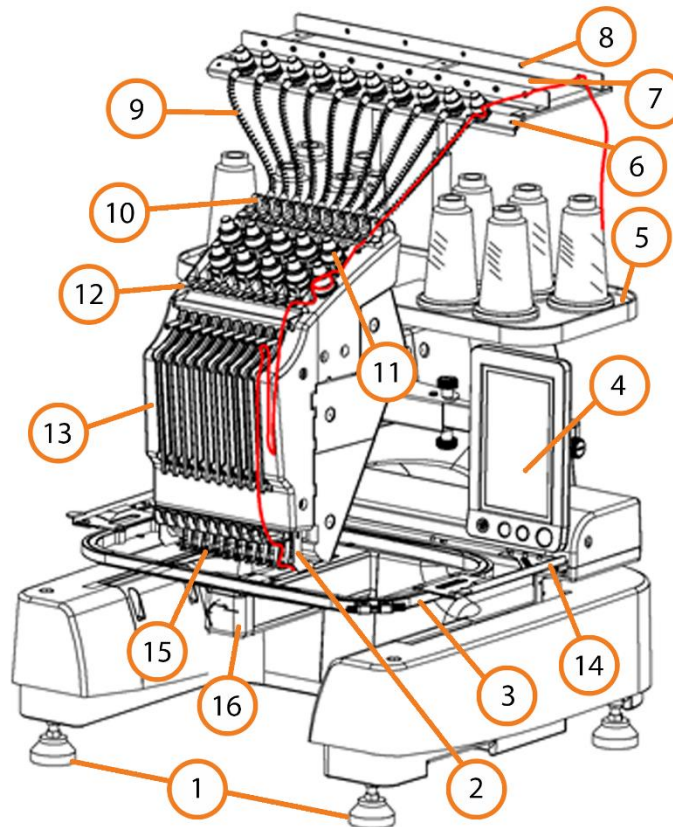

Figure 25

- |                               |                                 |
|-------------------------------|---------------------------------|
| 1. Base feet                  | 2. 10-needle bar                |
| 3. Embroidery hoop            | 4. Color LCD touch-screen panel |
| 5. 10 thread cone base        | 6. Thread guide                 |
| 7. Front thread guide eyelet  | 8. Back thread guide eyelet     |
| 9. Flexible thread guide tube | 10. Upper thread tension clip   |
| 11. Lower thread tension knob | 12. Lower thread tension clip   |
| 13. Needle bar frame          | 14. Flat frame support          |
| 15. Lower threading mechanism | 16. Bobbin housing unit         |



## Rear view

1. Thread guide rack
2. Plastic thread reel
3. 10 thread spool base
4. Manual wheel

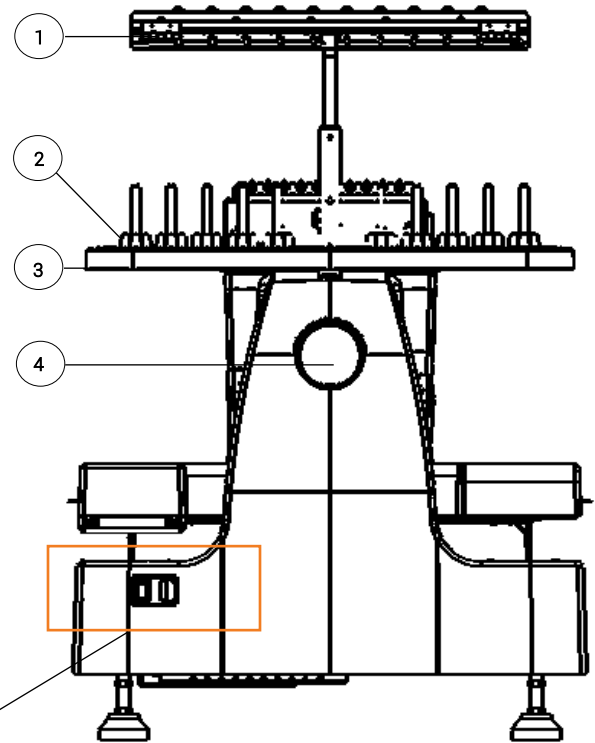

5. Power cord
6. Power switch (On/Off)

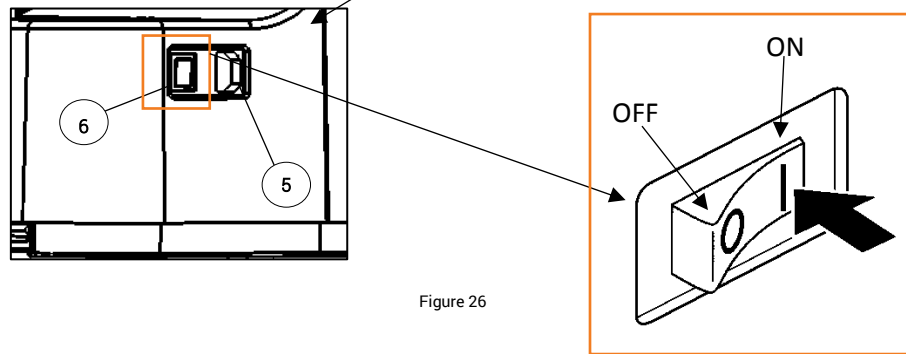

Figure 26

## Flat frame support

---

1. Left embroidery frame holder
  - Adjusts to fit different embroidery frames
2. Right embroidery frame holder
3. Embroidery hoop location

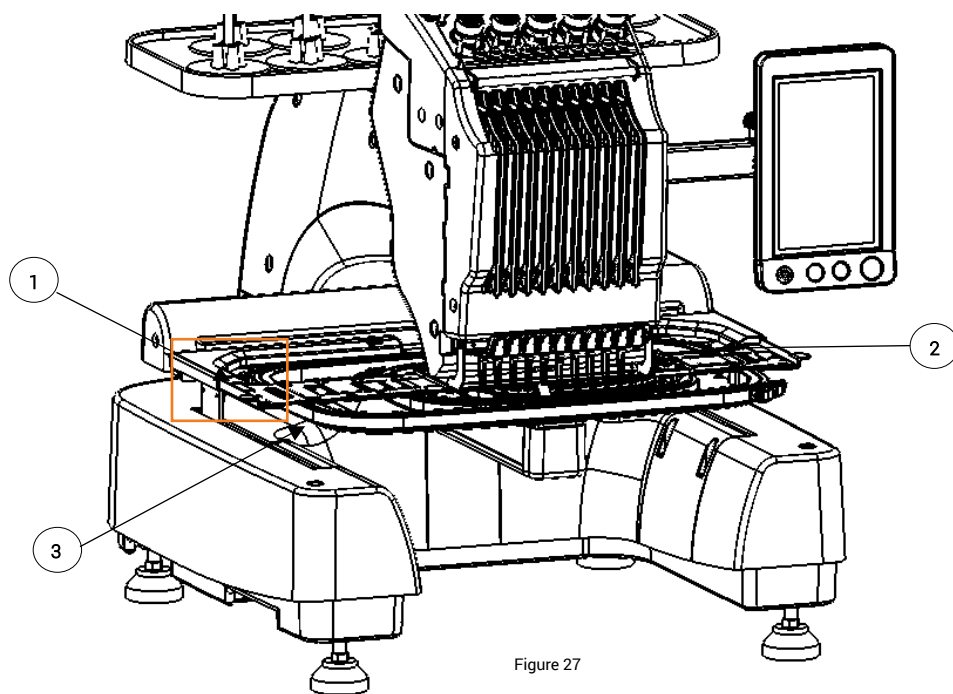
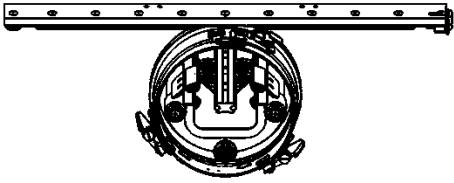
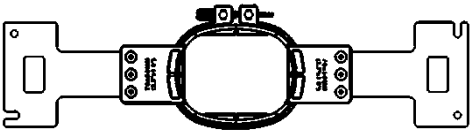
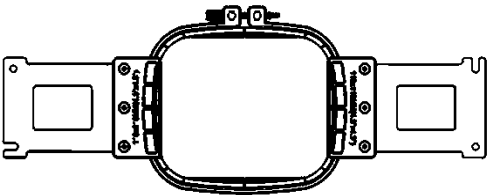
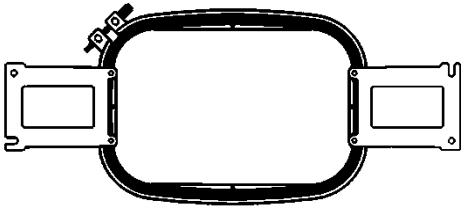
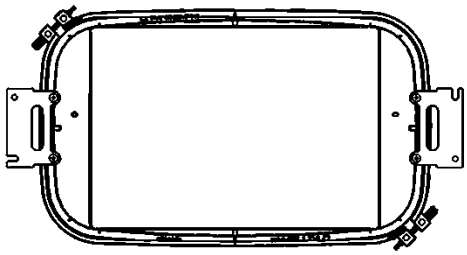

Figure 27

# Embroidery hoop specifications

Embroidery hoop	Name	Size
	Cap embroidery hoop	260 by 60 mm
	Embroidery hoop A	70 by 50 mm
	Embroidery hoop B	110 by 110 mm
	Embroidery hoop C	190 by 140 mm
	Embroidery hoop D	310 by 210 mm

## Touch-screen

1. Speaker
2. 100-degree button
3. Thread trimming button
4. Start/Stop button
5. Color LCD touch-screen panel

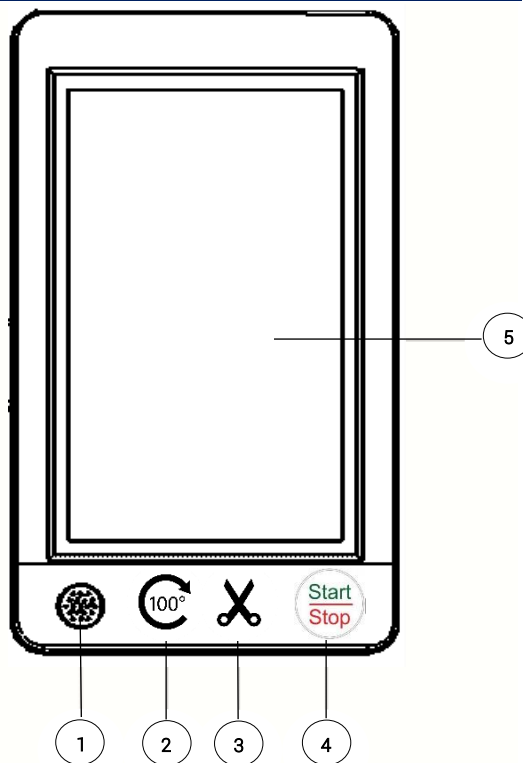

Figure 28

1. Computer network interface (insert internet cable)
2. USB port
3. Panel adjusting knob
4. Panel arm adjusting knobs

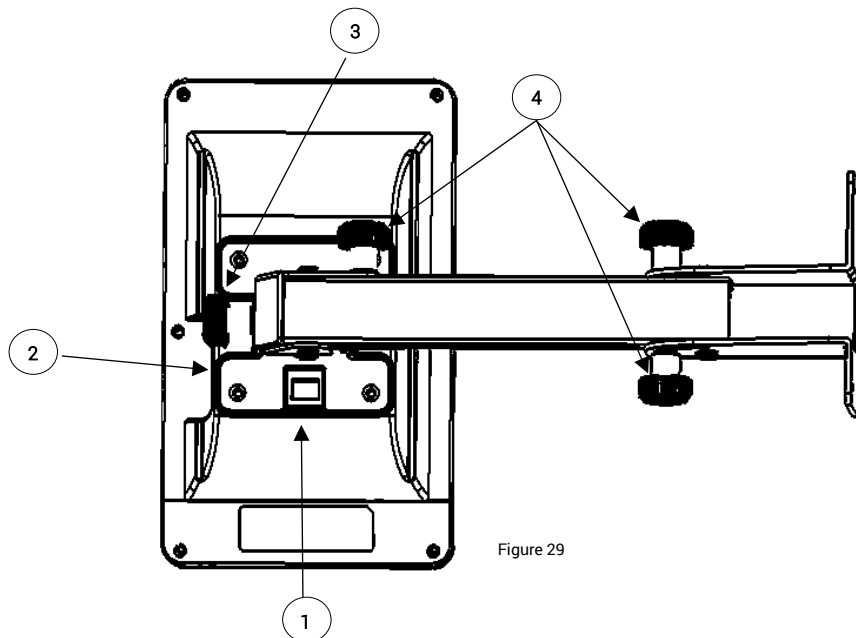

Figure 29

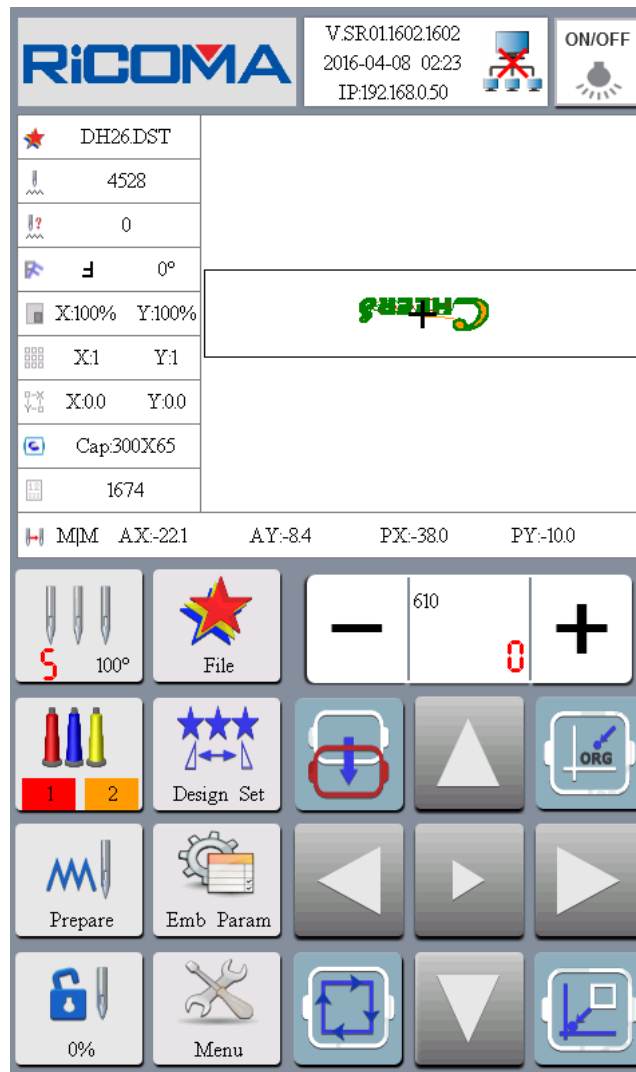

Figure 30

Image	Function	Function Description
	LED lamp switch	LED lamp ON/OFF switch
	Design preview zone	Displays the design selected, preview of embroidery frame position and embroidery progress
	Button function zone	General-purpose key, move frame, set embroidery machine, parameter, one-key frame movement, embroidery machine speed control, etc.
	Embroidery parameter display zone	Displays embroidery machine parameters, such as design name, number of stitches and embroidery frame type
	Embroidery machine networking process	Displays embroidery machine software version, date, time and embroidery machine's IP address

# BOBBIN OVERVIEW



- An “L” size/style bobbin must be used for your embroidery machine.
- The same steps apply whether installing or replacing a bobbin.
- The bobbin case can be found in the tool box.
- The rotary hook comes with a foam piece – remove before use.
- The embroidery machine will not indicate remaining quantity of bobbin thread. Before starting embroidery, ensure sufficient bobbin thread for the embroidery design.
- Clean the bobbin case when replacing the bobbin.
- Open the needle plate and clean the trimming set area weekly.
- Wind self-wound bobbins or buy pre-wound commercial bobbins in disposable cartridges.
  - **Note:** Self-wound bobbins tend to be inconsistent in the way the thread releases from the spool.
- Threads are available in spun polyester, filament polyester and nylon.
- If the bobbin runs out of thread, the embroidery machine will display a thread break (“T-break”) notification. See the [Thread break](#) section for more information.
- For a high speed, commercial embroidery machine, a smooth and consistent release of thread is required for proper function. Commercial pre-wound bobbins are economical and they run smoothly. It is better to run a polyester bobbin, not cotton a cotton bobbin because it leaves less lint.
- On average, bobbins usually last for about 35,000 to 42,000 stitches depending on the stitch length of your design.

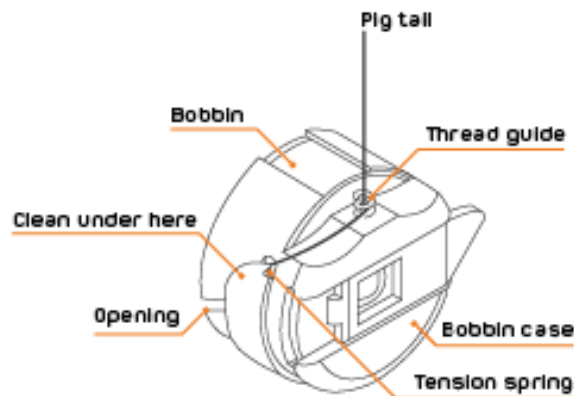

Figure 31

## Placing the bobbin into the bobbin case



- Inserting your bobbin correctly will help your embroidery machine run smoothly.
- An issue with the bobbin thread affects all needle bars.

1. Hold the bobbin with the thread in the clockwise direction. See Figure 32.
2. Insert the bobbin into the bobbin case. See Figure 32.

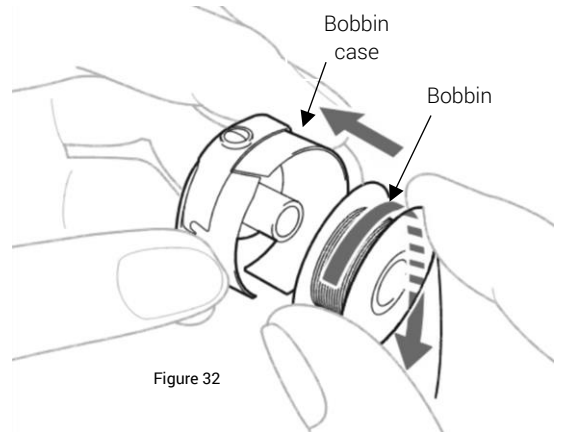

Figure 32

3. Pass the thread through the opening slit. See No. 1 in Figure 33.
4. Pull the bobbin thread under the tension arm and exit the notch at other end. See No. 2 in Figure 33.
5. Turn the bobbin over, and pull on the thread. See No. 3 in Figure 33.
6. Ensure the bobbin rotates in a clockwise direction. See No. 4 in Figure 33.

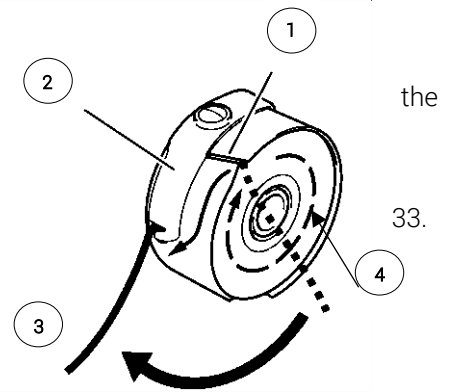

Figure 33

7. Wrap the thread around the pigtail twice. See Figure 34.

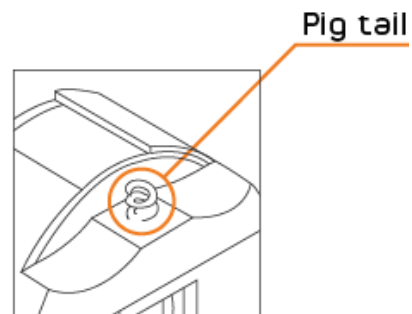

Figure 34



## Placing the bobbin case into the rotary hook

1. Grab the bobbin case by the bobbin case release latch and insert it into the machine. See Figure 35.
  - **Note:** Ensure the thread tail is no longer than three (3) inches. A longer tail can wrap around the shaft and create a “buildup” of thread. If the thread is not long enough, the needle will be unable to grab it.

2. Hold the bobbin case with the pigtail facing up. See Figure 40.
3. Insert the bobbin case into the rotary hook by aligning the bobbin case with the rotary hook groove. See Figure 35.

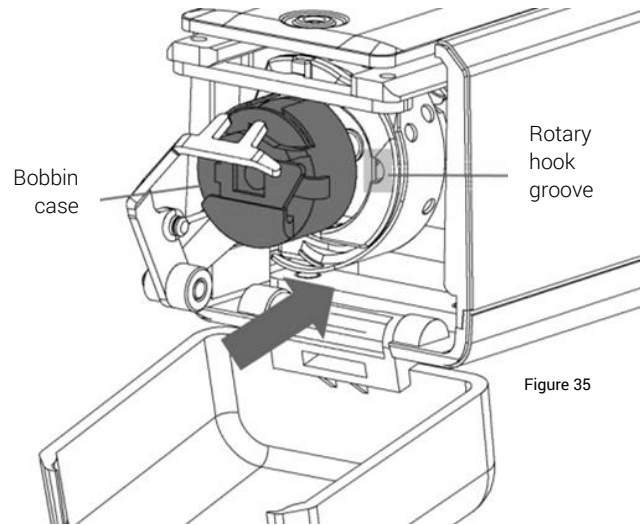

4. Push in the bobbin case slightly and ensure the bobbin case clicks into place. See Figure 36.

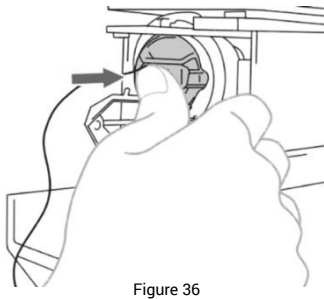

5. Close the bobbin housing unit. See Figure 37.

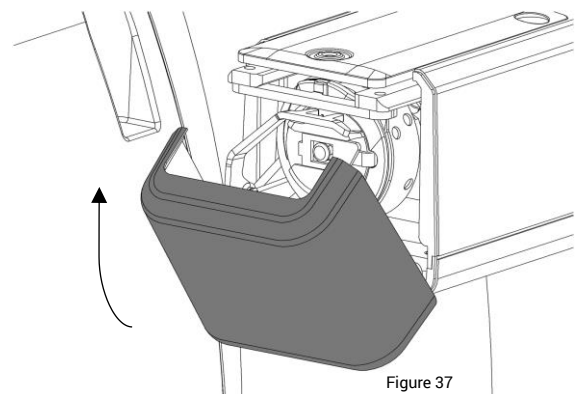

## Bobbin removal



- Use the following steps when replacing or rewinding the bobbin.

1. Open the bobbin housing unit. See Figure 38.
2. Identify the thread hook. See Figure 39. If thread hook is not forward, then pull it forward.
  - **Note:** Do not pull thread hook beyond its capacity. It only moves to a certain extent.

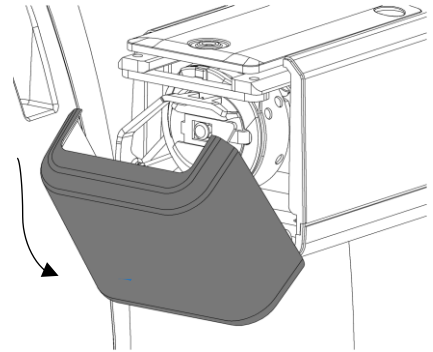

Figure 38

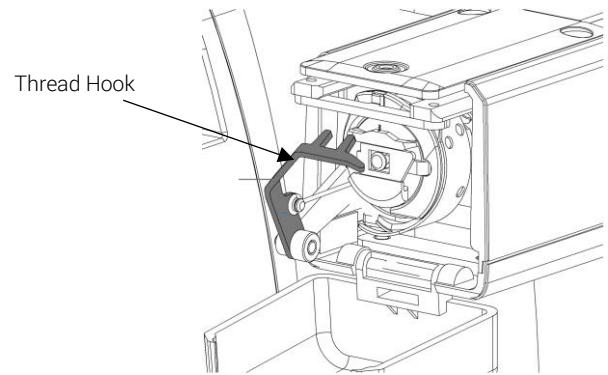

Figure 39

3. Grab the bobbin case by the bobbin case release latch. See Figure 40.
4. Gently remove the bobbin case from the machine.
5. Remove the empty or nearly empty bobbin from the bobbin case and discard or rewind.

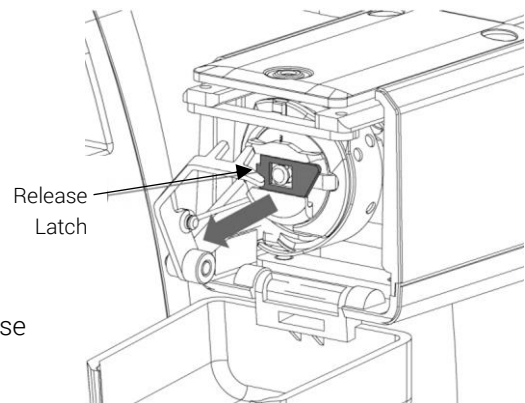

Figure 40

## Bobbin fiber choices

---



- Be sure to keep the tails no longer than three (3) inches.
- You might need to adjust the bobbin case, rather than the top tensioner if similar symptoms are exhibited on all needle bars.
  
- For lightweight threads, the weight is 60, 70 and 80. This specialty thread is used for fine fabrics, small delicate details and small fonts. If you are using this type of thread, increase density slightly by five (5) to ten (10) percent.
  
- For medium-weight threads, the weight is 30. This specialty thread can be used to fill large embroideries with fewer stitches. If you are using this type of thread, decrease stitch count by 15 percent; it saves production time. In addition, there is weight 35, which is most widely used for multi-color threads.
  
- For heavyweight threads, the weight is 12. This specialty thread creates the look of hand embroidery. If you are using this type of thread use long, floating stitches. There is special set-up time required for this thread. Adjust tension and needle change to 100 or 110.

### Cotton

- Not as strong as its synthetic counterparts
- Friendly texture, which allows for a wider range of adjustments in bobbin tension settings
- Releases lint, which has a tendency to collect under the bobbin tension plate
  - Lint build-up can lead to “springing” the tension plate – causing it to fail to hold any tension on the bobbin thread

### Nylon

- Very fine nylon, which is still quite strong, and therefore, a bobbin can hold many yards of thin nylon thread
- Small diameter and slick texture, which tends to make consistent tension on bobbin cases

### Continuous filament polyester

One long filament comprises the thread. These run much cleaner in the bobbin case and are much stronger. There are three (3) different sides of bobbins: (1) Paper sided – the most common; (2) Sideless – all thread with no sides; (3) Plastic sided – the plastic slides better and runs smoother in the bobbin case.

- Most popular thread amongst U.S. embroiderers
- Consistent, strong, thin, and reliable, high-quality thread
- Allows for no slub
- Allows for no lint
- Allows 127 yards to be held on a standard style “L” bobbin
- Can run a higher tension on both the top and bottom
- More expensive

## Spun polyester

Fibers are spun together to form a thread. The fibers on this bobbin have a tendency to shear off and usually, collect under the tension spring of the bobbin case. Over time, this may affect your tensions. It is not as strong.

- Texture similar to cotton
- Releases no lint
- Most economical and popular
- Requires less plate pressure
- With tight bobbin tension, can result in a narrow column or even a single strand of bobbin thread down the center of a satin column
  - This can cause the embroidery to unravel easily if the bobbin thread snags
- With loosening bobbin, tension will allow bobbin thread to be pulled by the top thread to the top side of the embroidery.
  - Even if the bobbin thread stays put on the underside of the work, chances are that columns will not have clean crisp edges
- With erratic bobbin, tension usually results from a catch in the bobbin case

## Magna glide

This type of bobbin has a magnet in the center, which helps keep more consistent tension on the bobbin thread. When using this type of bobbin, a gunmetal colored pieced in the bobbin case, called the brake, might need to be removed.

This section intentionally left blank.



# THREAD OVERVIEW

## Threading the embroidery machine/top threading



- To complete top threading, please operate carefully. Incorrect threading may cause thread or needle breakage.
- Follow the threading route as shown in Figure 42.
- Thread the embroidery machine as directed.
- The number represents the threading path for each needle bar.
- When upper thread color is changed, the user may cut off the thread between the cone and the thread guide hole to easily complete threading again.
- Place the new cone on the thread holder and connect the new thread to the previous thread, and then lead thread through the needle eye.

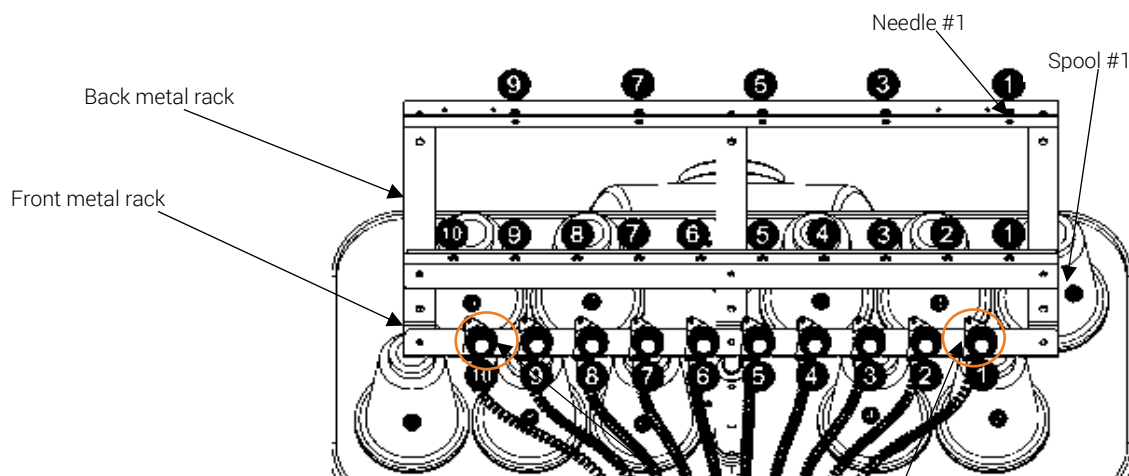

Raised lines (10)

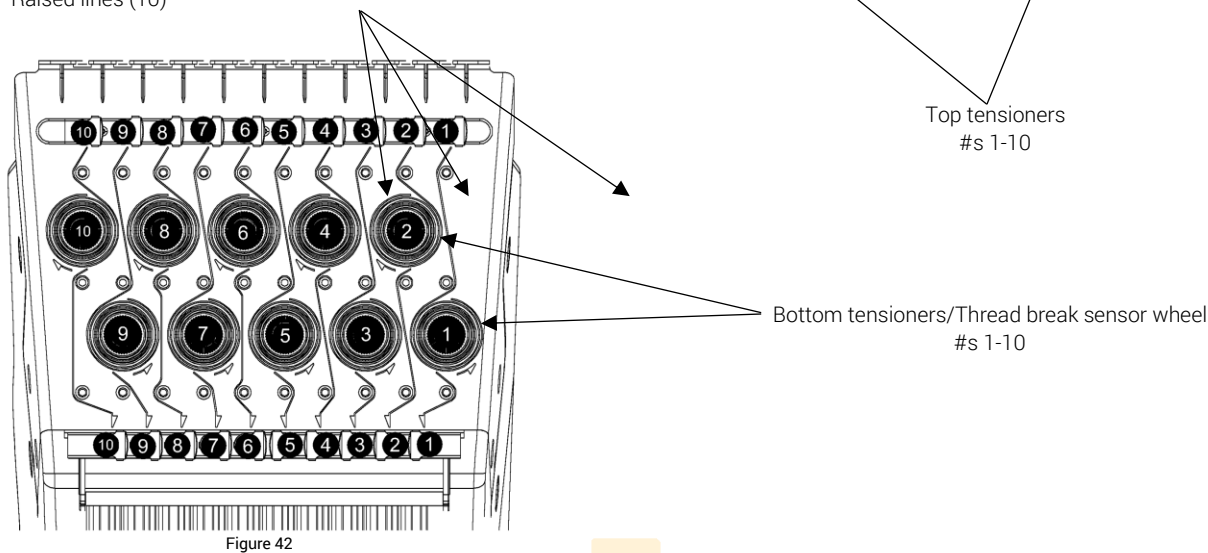

Machine head

Bottom thread course area

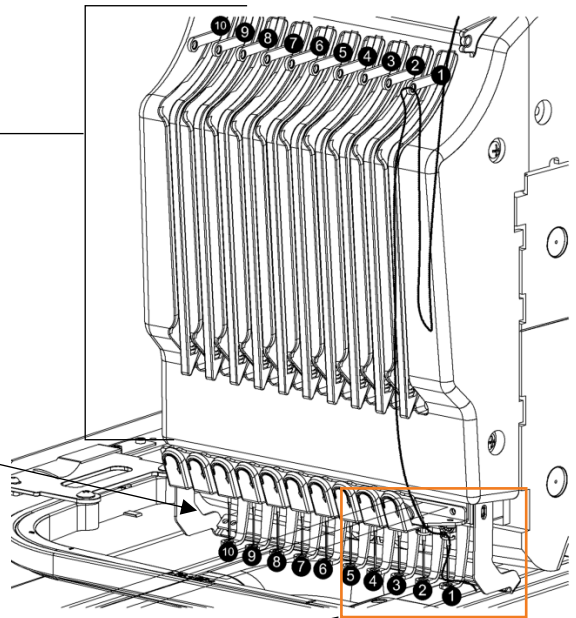

Figure 44

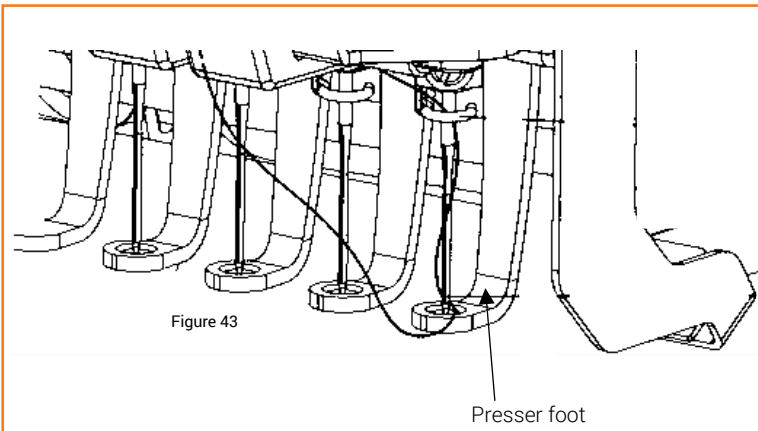

Figure 43

Presser foot

Threaded embroidery machine

Example: Needle 1

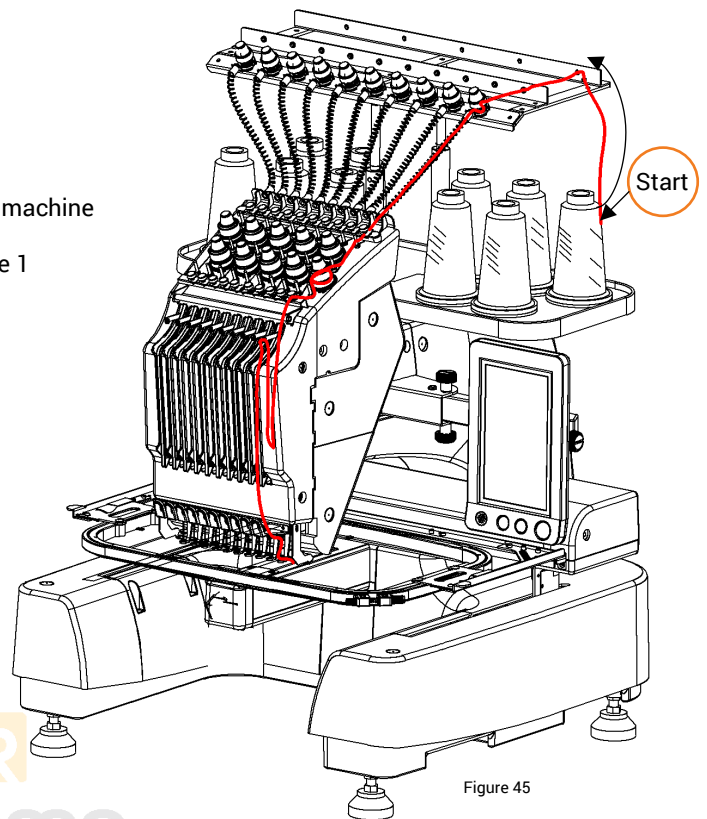

Figure 45



**Note:** For this procedure, spool #1 and needle #1 are used.

1. Pull out the thread from spool #1. See Figure 46.
2. Pass the thread through the bottom eyelet of the back metal rack. See No. 1 in Figure 47 .
3. Proceed to pull the thread through the vertical eyelet. See No. 2 in Figure 47.
4. Proceed to pass through the continuing corresponding eyelet of the front metal rack. See No. 3 in Figure 47.
5. Feed the thread through the eyelet of the top row of tensioners. See No. 4 in Figure 47.

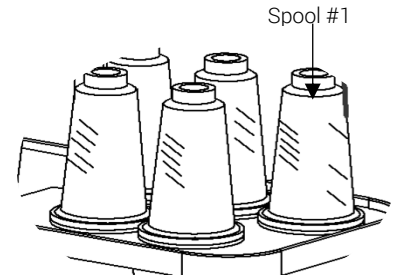

Figure 46

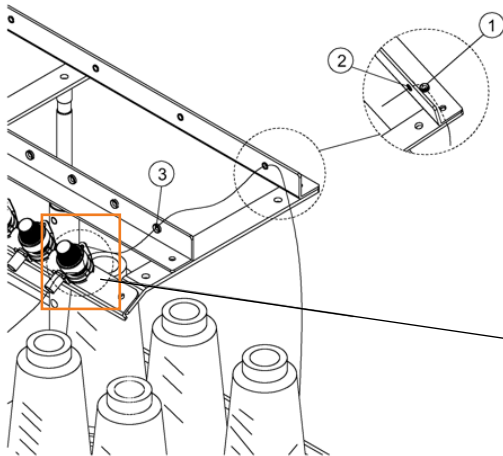

Figure 47

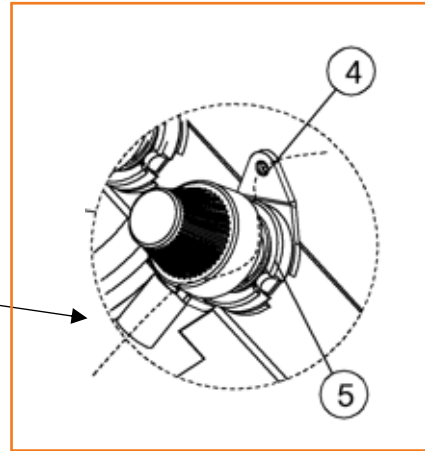

Figure 48

6. Pass thread in between of the tension plates (found underneath the tensioner knob). See No. 5 in Figure 47.
7. Remove the thread tension plastic tube. See Figure 49.
  - Grab a plastic end and pull up and then out.
  - Grab the remaining plastic end and pull up and then out.
8. Grab the threading tool.

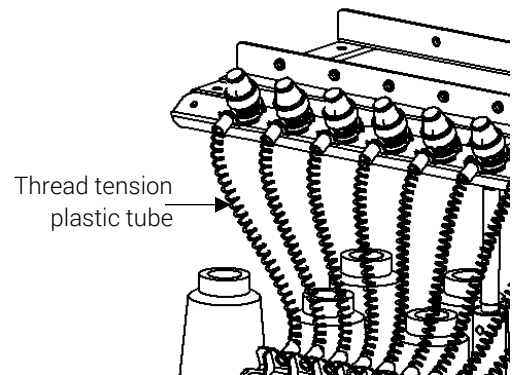

Figure 49



9. Hook the thread around the threading tool. See No. 3 in Figure 50.

10. Insert the threading tool into the removed plastic tube and follow the direction as seen in the example. See No. 1 in Figure 50.

11. Feed the thread tool, which is pulling the thread, completely through the plastic tube.

12. Unhook the thread.

13. Snap the plastic tube ends back into place.

14. Pull the thread out of the tube (enough thread to be able to continue threading down the machine head, down to the presser foot).

15. Lay it under the metal clip. See No. 1 in Figure 51.

16. Begin to follow the raised lines on the machine. To identify the raised lines, see Figure 42.

17. Upon reaching the tensioner (see No. 2 and No.3 in Figure 51), insert the thread between the tension plate (see No. 2 in Figure 51), found on the tensioner, pass the thread one and a half (1.5) times around the tensioner (see No. 3 in Figure 51).

18. Continue the thread to the lower pressing clip. Place the thread underneath the clip so the thread stays in place. See No. 4 in Figure 51.

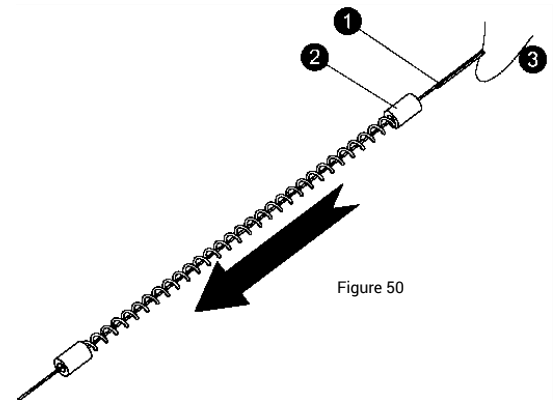

Figure 50

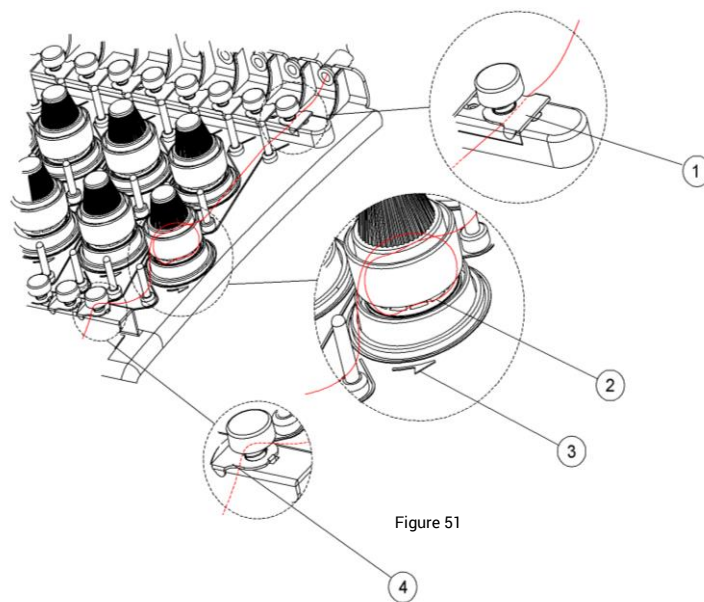

Figure 51



19. Continue the thread over the upper thread course.

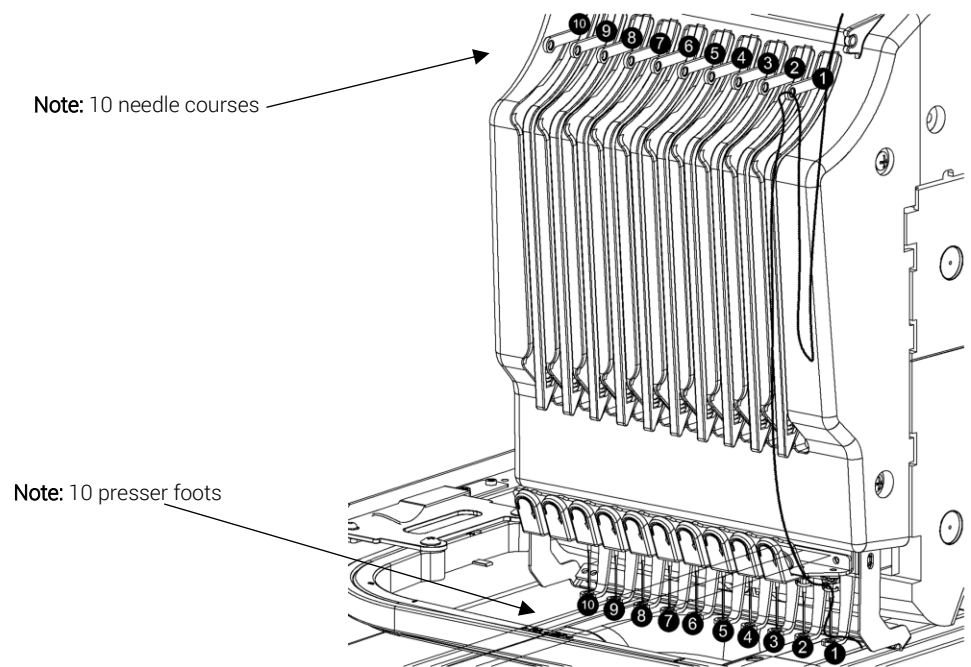

Figure 52

20. Insert the thread through the open gap. See Figure 52.

21. Pull the thread around the bottom of the divider to bring the thread up again. See No. 1 in Figure 54.

22.

23. Pass the thread through the take-up level eyelet, from the right to the left. See "A" in Figure 53.

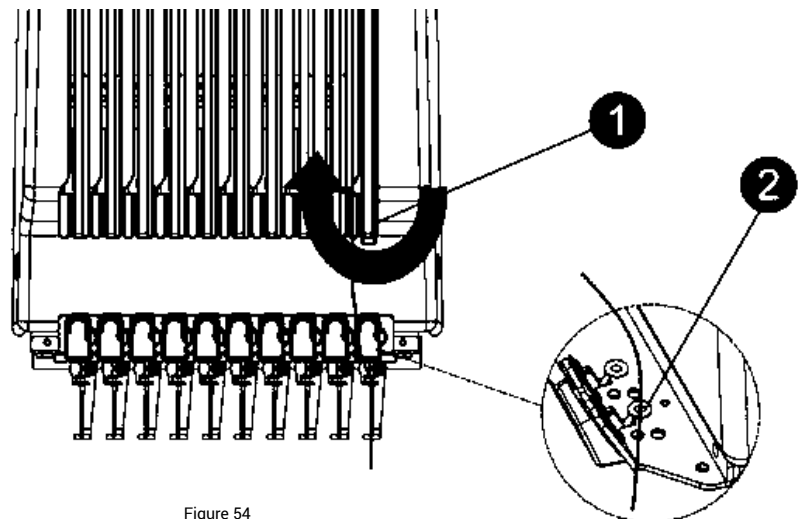

Figure 54

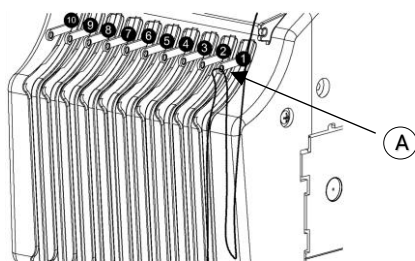

Figure 53

24. Take the thread back down and through the bottom eyelet. See No. 2 in Figure 54.

25. Proceed with the [Threading a needle](#) section to complete the threading process.

## Threading a needle

1. Pass the thread behind the thread hook. See No. 1 in Figure 55.
2. Feed the thread through the needle, from the front to the back. See No. 2 in Figure 55.
3. Proceed guiding the thread through the presser foot.
4. Pull the thread up and around the bottom thread course, from the left to the right. See No. 3 in Figure 55.
  - The extra thread will be cut.

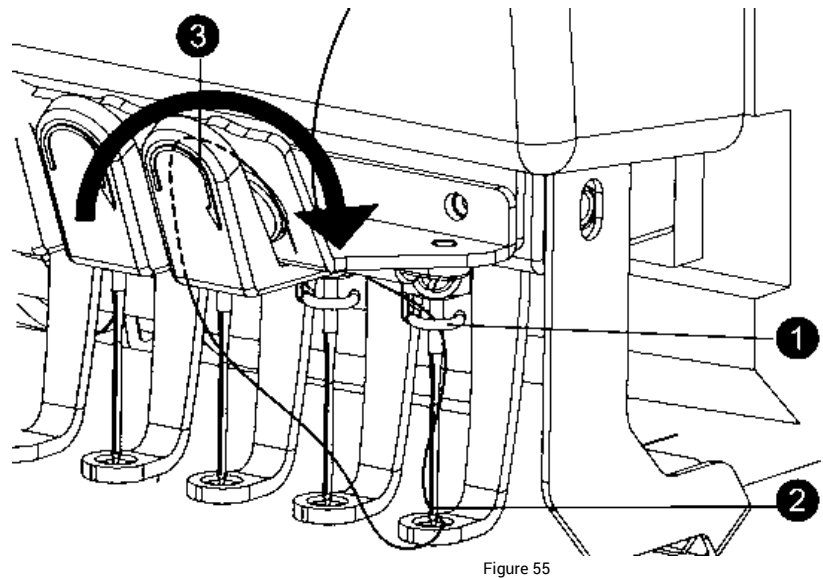
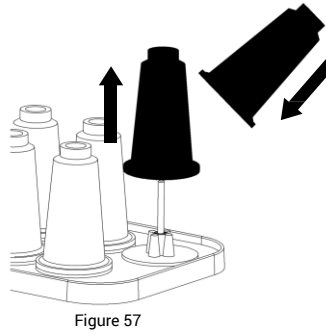
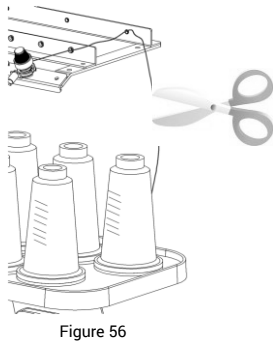

Figure 55

This section intentionally left blank.

# Changing the spool

1. Cut the thread from an existing spool. See Figure 56.



2. Place a new spool in its place. See Figure 57.
3. Unravel the thread from the spool. See Figure 58.

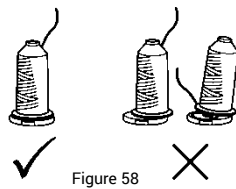

4. Attach the loose end of the new thread to the loose end of the old thread, creating a knot. See Figure 59.
5. Grab the thread from the presser foot, and pull the new thread all the way through until it reaches the needle.
6. Pull through a little more to allow the extra thread to hang.

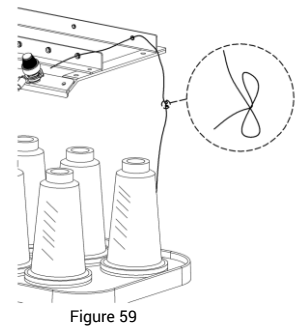

**!** If the knot does not make it past the needle, cut the thread and try passing it through the needle and presser foot again

## Knot tying

---

- Use a knot that will pull easily through the needle's eye.
  - The best knots are the square knot and the weaver's knot.

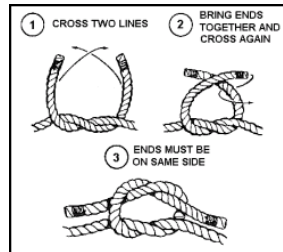

Figure 60

## Trimming

---

These instructions are for performing a manual trim.



1. Locate the icon that displays the scissors icon.
2. Press the scissors icon button.
3. Watch your embroidery machine trim the thread.

This section intentionally left blank.

## Thread fiber choices

---



- Lightweight threads are used for fine fabrics, small and delicate details and small fonts. The standard weight for lightweight threads is 60, 70 and 80.
  - If this type of thread is being used – increase density slightly by five (5) to ten (10) percent.
- Medium-weight threads are used to fill large embroideries with fewer stitches. The weight of a medium-weight thread is 30.
  - If this type of thread is being used – decrease stitch count by 15 percent.
  - Multi-color threads of medium weight have a weight of 35 (35 is the most widely used).
- Heavyweight threads are used to create the look of hand embroidery. The weight for heavyweight thread is 12.
  - If this type of thread is being used:
    - Use long floating stitches
    - Perform tension adjustment around 100-110 stitches
    - Perform needle change around 100-110 stitches
    - A special set-up time is required

### Rayon thread

- Available in sizes 30, 40 and 60
- Widely used by U.S. embroiderers
- More expensive than other fibers
- Beautiful, supple, friendly fiber
- Natural fiber made from cellulose
- Not one of the stronger fibers
- Handling properties are superior to other fibers
- Used for embroidery thread and looks very rich when sewn into fabric
- Slight equipment problems can cause an unacceptable number of thread breaks when using
- Susceptible to damage by environmental factors, such as light, heat and cold
- Black and white tend to break more frequently due to the bleaching and dyeing processes

### Polyester thread

- Excellent sewing ability
- Good choice for embroiderers
- May be too strong for certain lightweight, delicate goods
- Strong resistance to thread breaks, which can aid in production efficiency
- Can accept neon dyestuffs
- Excellent resistance to abrasion and bleaching
- Good choice for items that will be subjected to sunlight, chlorine or harsh laundering
- Polyester is stiffer than rayon, and it may require some tension or spring adjustment

## Metallic thread

- Stiffer than other varieties with an interesting construction
- Metallic film glued to a nylon or polyester core
- Quality varies widely among manufacturers
- If you have experienced difficulty in sewing with a metallic thread, try:
  - Using a smaller size metallic
  - Using a larger eye needle
  - Thread the metallic through the packing peanut attached to your thread tree
  - Check programming
  - Check density
  - Check stitch lengths

## Cotton thread

- Easy to adjust tensions
- Matte finish that is sometimes preferred to the shiny look of the other thread types
- Available in a broad range of sizes from very large to very fine

## Thread consumption

---

How much thread will you need for a particular job?

- Thread consumption varies according to the type of stitch.
  - Longer stitch lengths use more top thread than fill stitches.
    - A 5,000-yard cone yields about 9,000,000 stitches.
  - Bobbin thread yield is about 25,000 to 30,000 stitches per bobbin for style "L."
    - The amount of yards per bobbin varies according to thread type.

This section intentionally left blank.



---

# BACKING



- Used as stabilizer
- Foundation for a good embroidery
- Designed to support or even replace the fabric
- Helps hold the fabric as flat as possible to prevent distortion in the embroidery
- Different types of backings/stabilizers are used in embroidery
- The correct backing depends on the fabric being used
  - Heavyweight garments – use thin backing
  - Lightweight garments – use thick backing
- Comes in the color black or white
  - White is the most common and is used on most embroidery
  - Black is sometimes used on darker garments, especially if there is any chance the backing might be seen or bleed through, such as on pique knit shirts
- Comes rolled or pre-cut
  - Rolls are usually used on larger sewing areas
  - Pre-cut backing is more convenient for left chest type logos
- Backing comes in different weights. Choose the weight of the backing based on how much you need to stabilize the fabric. The goal is to eliminate the stretch. The more the garment stretches, the heavier the backing needs to be.
  - 1 oz. to 1.5 oz. – Lightweight
  - 2 oz. to 2.75 oz. – Medium-weight
  - 3 oz. to 3.5 oz. – Heavyweight

There are three (3) things you need to consider when choosing backing:

1. Stability of fabric:
  - Stretchy or loose fabrics require a heavy backing
  - Stable and tight woven fabrics require a light or medium backing
2. Stitch density:
  - Higher density fabrics require heavier backing
3. Washability:
  - Fabric washed frequently requires a heavy backing
  - Backing becomes softer after several washes

## Cut-away

---

- Weights range from 1 oz. (light) to 3.75 oz. (heavy)
- Used for permanent support – remains permanently affixed to the fabric – excess is cut away with scissors
- Provides the most stability
- Heat set fusible
- Offers the sharpest embroidery on highly detailed designs that include small lettering
- Used on loosely woven and unconstructed caps
- Best used on knits, since it prevents the design from stretching out with frequent washing or wearing
- When choosing cut-away:
  - Lightweight for a design with a light stitch density
  - Heavyweight for dense designs

## Tear-away

---

- Light support
- Comes in light to heavy weights
- Backing is removed by tearing off
- Use several layers of light to mediumweight backing for support
- Best used on firmly woven, natural-fiber fabrics
- Recommended for strong and stable fabrics, or for when you do not want the backing to show on the back, such as the backs of towels, caps, and bags
- Easier to remove one sheet at the time than using a heavier tear-away and trying to remove it

## Specialty backing

---

- Poly mesh/No show
- A lightweight woven cut-away that is soft, thin and strong
- Designed to provide extra stability on knit shirts
- Does not show through light color garments
- Used on low stitch count designs on polos and T-shirts
- Combine a no-show backing with a tear-away
- Removable with water or with heat

## Topping

---

- A plastic film used on the top side of an embroidered item to prevent stitches from shrinking into textured fabrics
- Used for temporary support
- Used on delicate, mesh-like and difficult to mark fabrics like pique, fleece or corduroy
- Requires the use of backing on the back of the fabric to support your fabric
- To remove the plastic film, tear-away the topping or use water

## Foam

---

- Adds dimension to lettering on caps for a 3D effect
- Available in a variety of colors
- Available in 2 mm and 3 mm sheets
- Laid on top of the area that will be dimensional and then stitched over with a column fill that uses short stitches to cut the foam
- Excess foam needs to be removed
- Pieces that remain can be easily eliminated by applying a hot hair dryer over the area





## Poly mesh backing

---

- Extremely thin backing that is extremely strong due to its fibers
- Used to add a lot of stability, without the bulk of a heavyweight cut-away backing
- Great for the newer tech garments that are very thin and contain fluidity to the fabric
- Adds stability without running the movement of the garment
- If needed, use two pieces of poly mesh on a stretchy material

## Fusible backing

---

- Used on stretchy materials
- Once fused to the garment, the garment and the backing become one
- Stable material
- Cover up a finished piece of embroidery, such as an infant's onesie, where the stitches and the backing could irritate the baby's skin

This section intentionally left blank.



---

# BACKING + NEEDLE RECOMMENDATIONS

## Canvas

Use a light to medium tear-away. Sharp needles are better for longer runs. We recommend using a 75/11 sharp or normal round point needle.

## Canton fleece

Use light tear-away polyester backing to maintain colorfast-ness if a garment is subjected to extensive sunlight, chlorine, salt water or industrial laundering and bleaching. We recommend using a 75/11 light ballpoint needle.

## Coated or waterproof

Use a light to heavy tear-away backing. We recommend using a 75/11, 80/12 sharp or light ballpoint needle.

## Corduroy

Use a medium topping and light to medium tear-away. We recommend using a 75/11 light ballpoint needle.

## Cotton sheeting

Use a heavy cut-away or tear-away/wash-away. Great for children's clothing. We recommend using a 75/11 light ballpoint needle.

## Denim

Use a heavy cut-away or tear-away/wash-away. We recommend using a 75/11 light ballpoint needle.

## Dress shirt (woven)

Use a heavy cut-away or tear-away/wash-away. We recommend using a 75/11 or 70/10 light ballpoint or 80/12 needles for small details.

## Golf shirt

Use a light to heavy cut-away. Heavy knits require a medium to heavy cut-away; medium knits require a light cut-away. We recommend using a 75/11 light ballpoint needle.

## Headwear

Use a medium to heavy tear-away. We recommend using a 75/11 or 80/12 sharp needle.

## Leather and vinyl

Use a light tear-away. We recommend using a 75/11 or 80/12 light ballpoint needle on stiff or spongy leather (upholstery luggage). We recommend using a 70/10 or 80/12 sharp needle on soft, supple garment leather.

## Lingerie or silk

---

Use a water-soluble tear-away backing. We recommend using a 70/10 light ballpoint needle or 80/12 needle depending on the thread.

## Lycra or spandex

---

Use a medium cut-away or water-soluble tear-away. We recommend using a 70/10 medium ballpoint needle.

## Nylon windbreaker

---

Use a light to heavy cut-away. We recommend using a 75/11 light ballpoint needle.

## Satin jacket

---

Use a light to heavy cut-away. Cotton-on-cotton is a nice look. We recommend using a 75/11 light ballpoint needle.

## Sweater knit

---

Use a medium to heavy cut-away. We recommend using a 75/11 light ballpoint needle.

## Sweatshirt

---

Use a heavy tear-away or cut-away. We recommend using a 75/11 light ballpoint needle.

## T-shirt

---

Use a light, water-soluble tear-away or medium cut-away. We recommend using a 75/11 light ballpoint needle.

## Terry cloth

---

Use a medium-weight, water-soluble tear-away and topping. We recommend using a 75/11 or 80/12 light ballpoint needle.

This section intentionally left blank.

# BEFORE GETTING STARTED

## ! Important

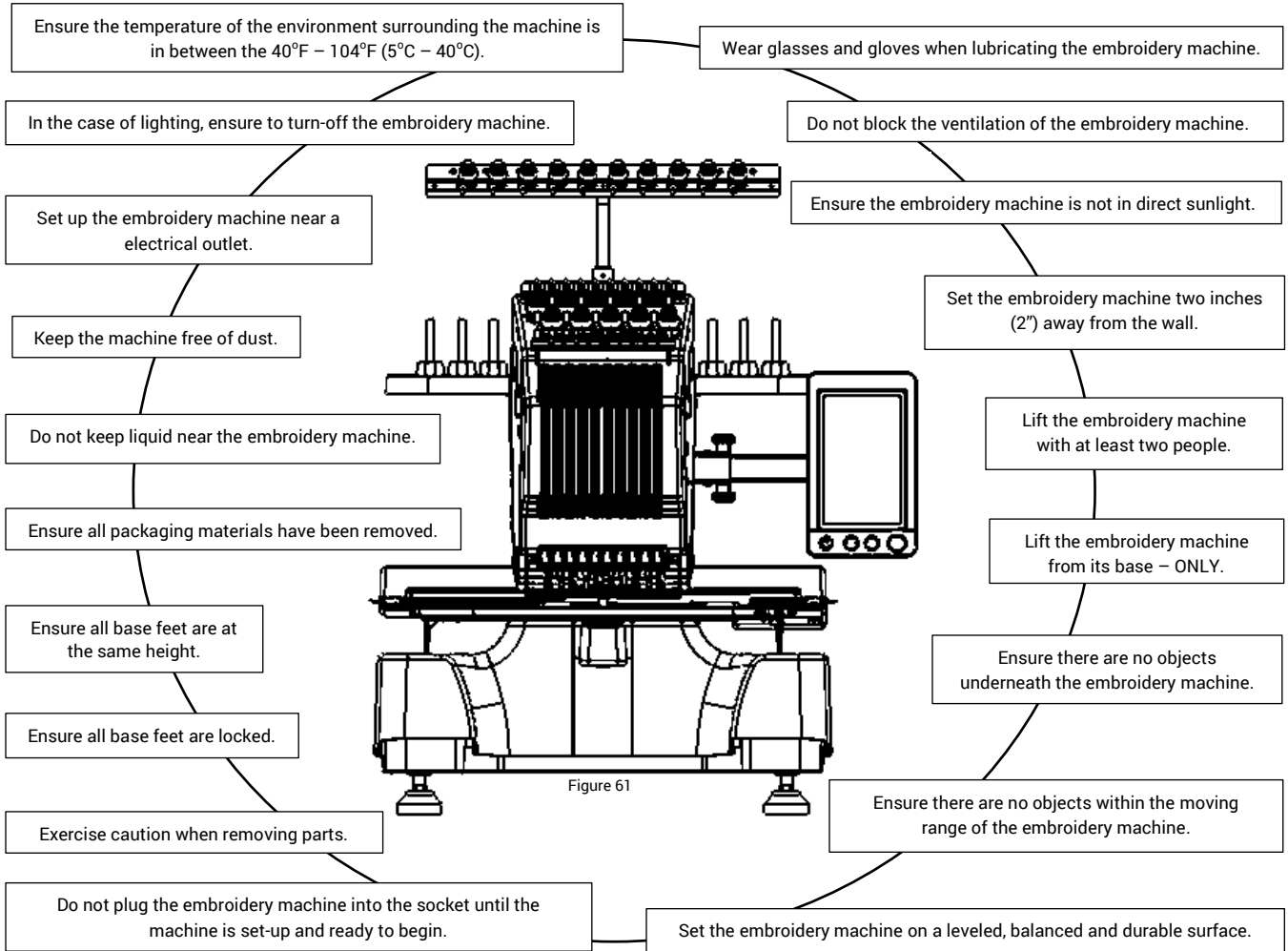

# GETTING STARTED



To prevent injury, keep hands and other objects away from the needle bar rack.

- The main power switch is located on the back of the embroidery machine.
- The “O” icon turns the embroidery machine OFF.
- The “I” icon turns the embroidery machine ON.
- Once the embroidery machine is turned on, the needle bar rack will automatically move to the position of the number five needle bar.

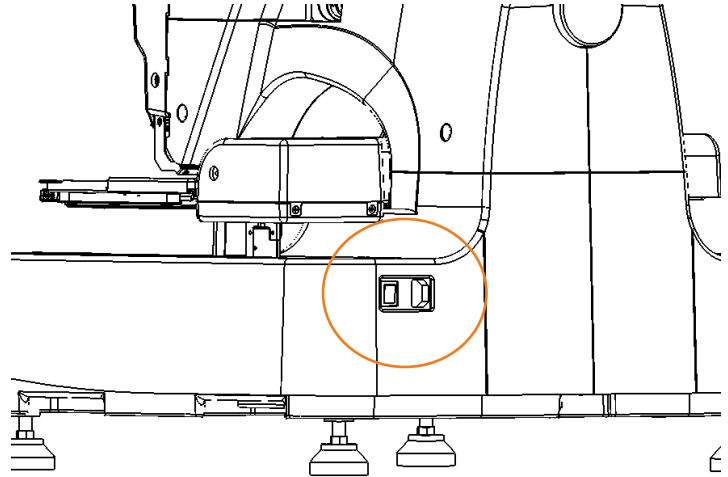

Figure 62

## Turning on

1. Insert the power cord into the back of the embroidery machine.
2. Connect power supply cord to an electrical outlet.
  - A surge protector is highly recommended.
3. Move the main power switch on to “I.”
  - The needle bar rack will automatically move to the position of needle bar #5.
  - The LCD will turn on.

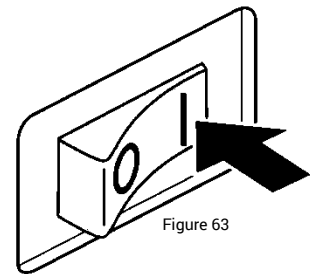

Figure 63

## Turning off



- To prevent injury, ensure embroidery machine is turned off when not in use.
- In the case of a power outage, while the embroidery machine is in use, perform steps one (1) and two (2) identified below.

1. Move the main power switch to “O.”
2. Disconnect the power supply cord from the electrical outlet.
3. Disconnect the power supply cord from the embroidery machine.



Figure 64



# CONTROL PANEL OVERVIEW

The control panel is a touch-screen comprised of two (2) sections:

1. The display at the top half of the screen.
2. The keys on the bottom half of the screen.

There are five pages that display on the touch-screen depending on the function intended to complete:

1. Home page
2. Logo selection page
3. Color sequence selection page
4. Design setting page
5. Comprehensive setting page

Page #1 – Home



Figure 65

Page #2 – Logo selection



Figure 66

Page #3 – Color sequence selection



Figure 67

Page #4 – Design setting

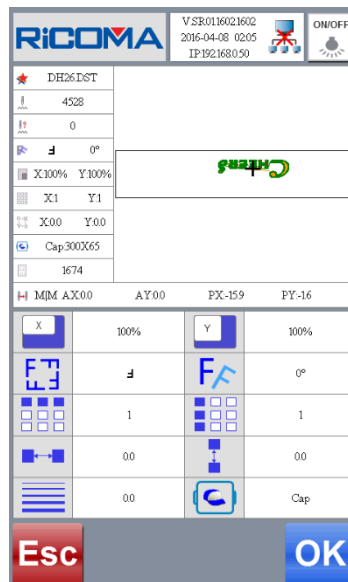

Figure 68

Page #5 – Comprehensive setting

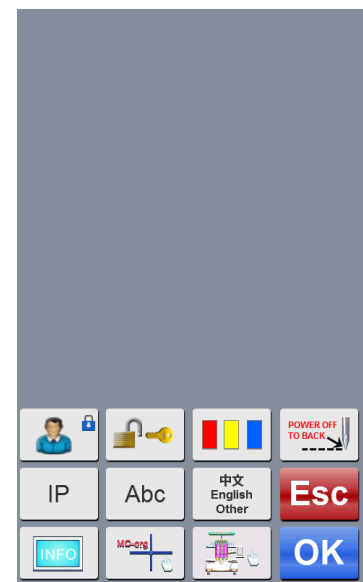

Figure 69

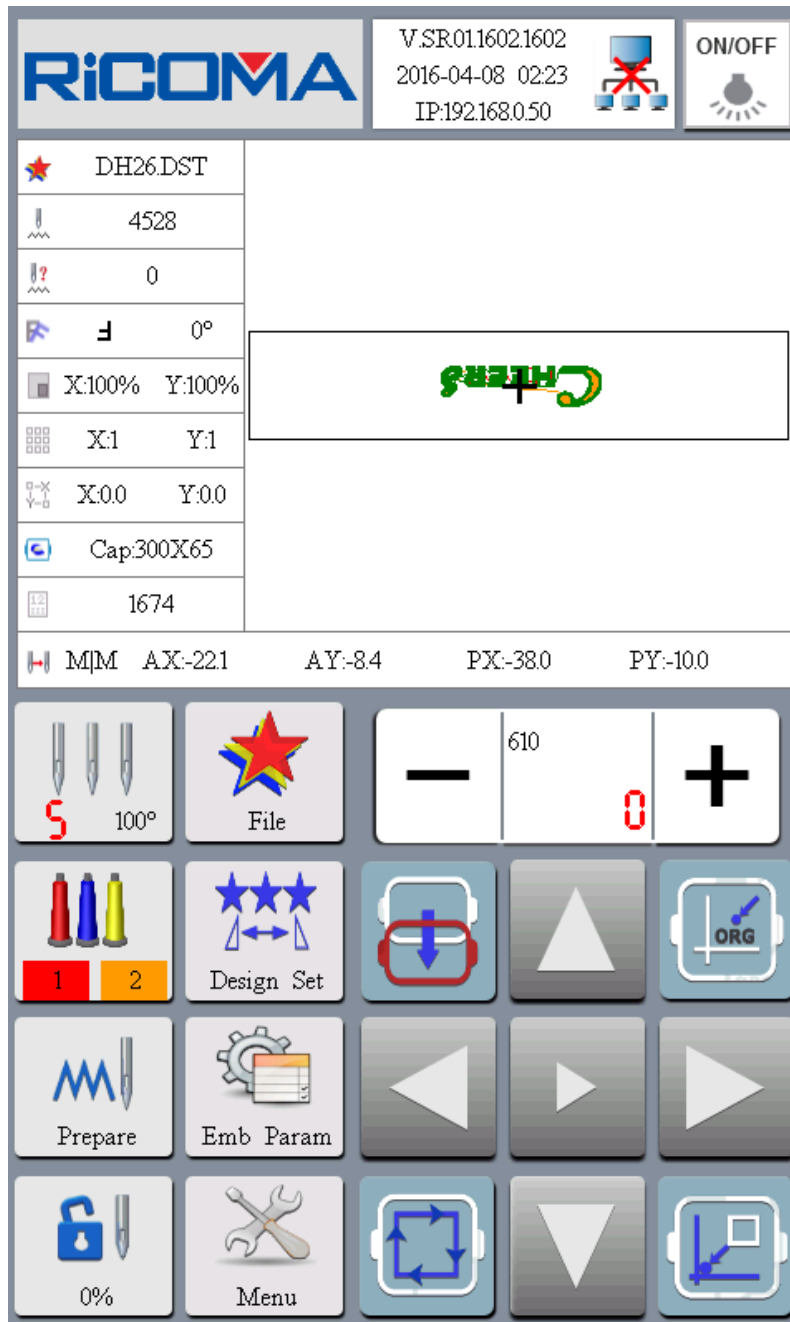































Figure 70

Icon	Function	Icon	Function
	Display design name		Logo
	Display design stitch numbers	V.SR01.1509.1508 2015.10.10 10:10 IP:192.168.1.2	Display software version, date, time and IP address
	Display current number of stitches		Display networking status
	Display design direction and rotation angle		LED lamp on/off switch
	Display design scaling		Design display
	Display array number		Display the range of current embroidery frame
	Display X and Y position	—	Reduce embroidery speed
	Display size of embroidery frame	+	Increase embroidery speed
	Display coordinate parameter		Frame offset
	Display current position of needle		Return to starting point
	Design selection and management		Control frame movement in Y direction
	Color setting and color change mode switchover		Control frame direction movement in X direction
	Set design parameters		Switch over high/low speed of frame movement and raise/lower machine speed
	Display X and Y position		Control frame movement in X direction
	Display stitch floating mode		Control frame movement in Y direction
	Embroidery parameter setting		One-step tracing key to check embroidery image
	Enter/exit ready status		Contour tracing
	Comprehensive setting		Go to end point



## Logo selection page







Icon	Function
	Switch to external storage
	Switch to internal storage
	Previous page
	Next page
	Delete a design
	Save design in embroidery machine memory

No.	Name	Stitch	✓
11	RICLOG~1DST	3546	
12	RCMQUA~1DST	2883	
13	DESIGN2DST	276721	
14	330A.DST	5284	
15	ZMK14.DST	1023	
16	DH26.DST	4528	
17	KAREN1DST	3827	
18	XGEBE3~1DST	5710	
19	ZMK18.DST	571	
20	DH26.DST	4528	★

Figure 71

## Color sequence page

Icon	Function
	Set offset point
	Low-speed embroidery
	Switching needle bar
	Color change mode
	Previous page
	Next page



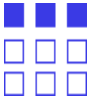









Figure 72

## Design setting page

Icon	Function
	X-direction scaling
	Design rotation angle
	Number of X-direction array
	X-direction array space
	Satin stitch compensation
	Y-direction scaling
	Design rotation angle
	Number of Y-direction array
	Y-direction array space
	Status of current embroidery frame

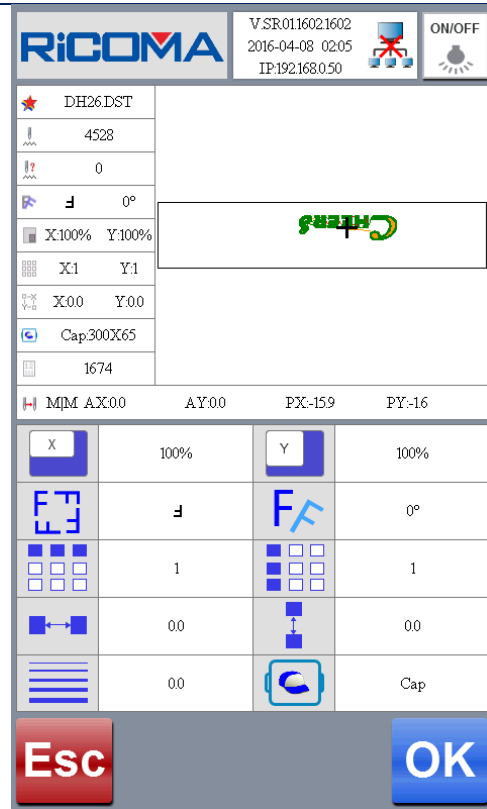

Figure 73

## Comprehensive menu settings page











Icon	Function
	User restriction setting
	IP setting
	On-board lettering library
	Software information
	Origin operation
	Relieve user restriction
	Display color setting
	Power-on automatic resetting
	Language setting
	Embroidery machine testing



Figure 74

# CONTROL PANEL FUNCTIONS

## Start/Stop



- Before starting to embroider your selected design, ensure that there is no object within the work area of the embroidery hoop. If the embroidery hoop collides with something, the embroidery design will misalign.
- The Start/Stop button is located at the bottom right-hand corner of the control panel.



Figure 75

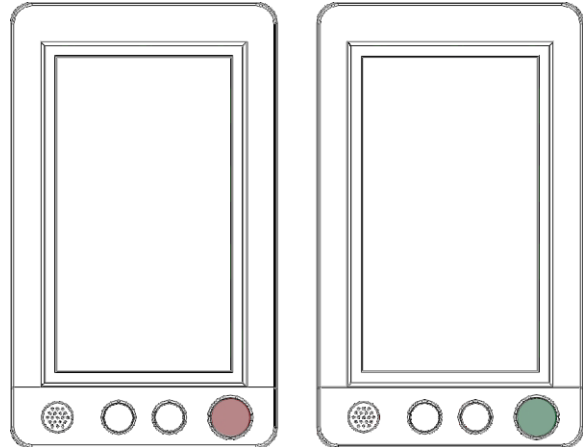

- If the embroidery machine is off, the Start/Stop button will illuminate GREEN when pressed.
- If the embroidery machine is on, the Start/Stop button will illuminate RED when pressed.

### To start

1. Press the Start/Stop button.
2. Allow the embroidery machine to complete the first color thread.
  - The current thread will automatically trim.
  - The needle bar case will move to the position of the second color thread and resume embroidery.

**Note:** Allow the embroidery machine to continue its process until the last color thread has completed.

- The embroidery machine will automatically stop. The Start/Stop button will illuminate red and a buzzer will sound.

### To stop

1. Press the Start/Stop button.
2. Ensure the button illuminates RED.



## Importing/uploading a design



- Ensure that the file intending to be uploaded into the embroidery machine is a .DST file. If the file is not a .DST file, the embroidery machine will not recognize it.
- If your embroidery file is in another file type, you will need to change the file type by using the provided Wilcom Hatch software.

1. Insert the memory drive into the right side of the panel. See Figure 77.

2. Ensure that the embroidery status is set to unlocked.



3. Press the file icon.



- A new screen will display.

4. Press the memory stick icon.



- A list of available files located on the inserted memory stick will appear.
- You can turn the pages by pressing the forward and backward arrows.



5. Locate your desired design and select it.

- An image of the design will appear on the touch-screen, along with a star icon on the right-hand side of the panel.

6. Press the transfer icon.



- A message reading "Loading" will appear on the screen.

7. Press the OK button.

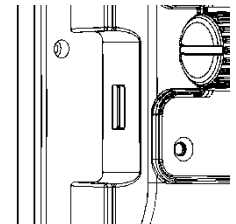

Figure 77

This section intentionally left blank.

## Selecting a design

1. Ensure that the embroidery status is set to unlocked. For instructions on how to set the embroidery status to unlock, see the [Embroidery status](#) section.







2. Press the file icon.
  - A new screen will display.
3. Locate your desired design in the list of files, and then select it.
  - An image of the design will appear on the touch-screen, along with a star icon on the right-hand side of the panel.
4. Press the OK button.
  - A message indicating "Reading" will appear on the screen.
  - Once the embroidery machine completes reading, you will be taken back to the home screen.

## Selecting an embroidery hoop

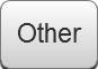

1. Press the design set icon.
  - A new screen will display.
2. Press the embroidery hoop selection icon.
 
3. Locate the image of the desired embroidery hoop. See table below for images of each embroidery hoop.
4. Press the OK button.
  - A message indicating "Reading" will appear on the screen.
  - Once the embroidery machine completes reading, it will position itself into the correct preset embroidery hoop position.

Icon						
Name	Cap embroidery hoop	Embroidery hoop A	Embroidery hoop B	Embroidery hoop C	Embroidery hoop D	Others
Embroidery Area	260 by 60 mm	70 by 50 mm	110 by 110 mm	190 by 140 mm	310 x 210 mm	
Embroidery Area	260 by 60 mm	70 by 50 mm	110 by 110 mm	190 by 140 mm	310 x 210 mm	

## Selecting the color sequence

---



1. Press the color sequence icon.



2. Locate and select the desired color.

- Select the colors according to the color stop sequence identified in the embroidery software/run sheet.
- The first box will display in blue.

3. Press the needle selection number.



**Note:** Print the color analysis/color film sheet from the embroidery software, in order to know the color sequence of the design.

4. Repeat step two (2) until all colors and needle selections have been made.

5. Press the OK button.



- You will be taken back to the home screen.

This section intentionally left blank.



## Color change mode

---



- The EM-1010 has three (3) color change modes. The color change modes allow for a fully automatic (A/A), semi-automatic (A/M) or manual (M/M) process.
- Color changes take place according to the color sequence selections made for the design.



A/A is for fully automatic mode – this is the default selection.

- There will be no stops between color changes.



A/M is for semi-automatic mode.

- The embroidery machine will stop upon completion of each color stop. Press the Start/Stop button to resume.



M/M is for manual mode.

- The embroidery machine will stop upon completion of each color stop. This option is to be used along with needle selection.

1. Press the color sequence icon.
  2. Locate the color change mode icon.
  3. Press the color change mode icon once to change the mode from the default fully automatic mode to semi-automatic, or press the color change mode icon twice to change to the manual mode.
  4. Press the OK button.
- You will be taken back to the home screen.

## Needle switch display icon

---



- Under this option, a manual move of the machine head to a specific needle number can be performed.

Optional

- Select needle #1 (tracing needle) before starting a new logo.





## Embroidery design trace



- When the design exceeds the range of the embroidery hoop, the preview line surrounding the design will appear in red.
- When the design is within the embroidery hoop range, the preview line will be in black.
- Embroidery design tracing should take place before beginning a new design to ensure the selected design and the frame embroidery hoop are in coordination.
- The option to complete a contour tracing is available afterwards.



1. Press the trace design icon.
  - The embroidery hoop may automatically move within the maximum range of design, and if the position of the needle is not correct, the embroidery machine will position itself accordingly.
2. A message stating, "Enter embroidery status?" will display.
3. Press OK.

## Using float mode



- Float is used to describe fast-forwarding or rewinding. This feature can only be accessed when the embroidery machine is on a locked embroidery status mode. To check the status of the embroidery machine, see the [Embroidery status](#) section.

F.L represents floating on low speed.

F.H represents floating on high speed.

ADD represents manual mode.

1. Press the stitch floating mode icon.
  - Pressing the stitch floating mode icon once will display the "F.L" icon.
  - Pressing the stitch floating mode icon twice will display the "F.H" icon.
  - Pressing the stitch floating mode icon thrice will display the "ADD" icon.



**To rewind or fast-forward a design, either in F.L or F.H mode,**

- 2a. Press and hold the plus (+) or minus (-) icon until you reached your desired placement.

**To rewind or fast-forward a design in manual mode,**

- 2b. Press to enter the exact location by stitch amount.

Press to subtract by stitch amount to reach your exact location.

Press to travel from one color sequence to another.

3. Once you have reached the desired position, press the stitch floating mode icon until you exit from the options.
4. Press the Start/Stop button to resume the embroidery.

## Frame out



- This function is used to select a low speed option to a specific or a group or specific needles or colors to allow the needle to work on a lower speed.



1. Press the color sequence icon.
  - The color sequence page will display.

2. Select the needle or color you wish to add the frame out sequence to.



3. Select the needle you desire.



4. Select the frame-out icon (F).
  - This will add the letter "F" to the selected needle number for identification purposes.
  - Repeat steps three (3) and four (4) until all your needle selections have been made.

5. Press the OK button.

- You will be taken back to the home screen.

This section intentionally left blank.



## Low speed

---



- This function is used to select a low speed option to a specific or a group or specific needles or colors to allow the needle to work on a lower speed.



- Press the color sequence icon.
  - The color sequence page will display.

- Select the needle or color to be reduced in speed.



- Select the needle you desire.



- Select the low speed icon (L).
  - This will add the letter "L" to the selected needle number for identification purposes.
  - Repeat steps three (3) and four (4) until all your needle selections have been made.

- Press the OK button.

- You will be taken back to the home screen.

## Trimming

---



- This function is used for a manual trim of a desired thread.



- Locate the icon that displays the scissors icon.
  - The thread is now trimmed.



## Embroidery status

---



- This function is used to determine if the embroidery machine is in setup mode (unlocked) or in embroidery mode (locked).

To begin a new design,



1. Locate the embroidery status icon.
2. Identify if it is locked or unlocked.
3. If it is unlocked, continue with setting up the new design, or  
If it is locked, press the embroidery status icon.
  - The following message will prompt, "Remove embroidery status?"
4. Press OK to confirm.

## Tracing the embroidery area

---



- This function is used to determine if the design to be embroidered has been properly positioned.



1. Press the trace design icon.
  - The following message will prompt, "Enter embroidery status?"
2. Press OK to confirm. .
- The embroidery machine will now begin to trace the set design.
- Follow the tracing needle to ensure that it stays within the embroidery hoop range.

## Deleting a design

---



- This function is used to delete a design from the memory of the embroidery machine.

1. Press the file icon.



- A new screen will display.

2. Press the embroidery machine memory icon.



3. Press the desired design to delete in the upper portion of the screen.

- A star will appear to the right of the design, and the design will appear on the lower part of the screen.

4. Press the icon marked by a blue "X".



- A message stating "Delete Design?" will show.

5. Press OK.



## Adding a font

---



- This function is used to add a desired font to a design. Ensure that the embroidery status is unlocked. For instructions on how to set the embroidery status to unlock, see the [Embroidery status](#) section.

1. Press the menu icon.



2. Press the ABC icon.



3. Type the letters or words desired for the design.

4. Press OK.



5. Select a font.

6. Press OK.



- The newly added letters or words will display on the screen.
- At this time, you may edit the design further.

7. Press OK.



8. Press the import to screen icon.



9. Press the escape button three (3) times.



- You will be back at the home page.

10. Click the file icon. 

- The font design will be displayed on the design list.

11. Select the design.

12. Add colors. 

13. Press the trace design icon. 

- The following message will prompt, "Enter embroidery status?"

14. Press OK. 

- The embroidery machine will position itself at needle one (1) and begin the tracing of the design.

## How to abort a job

---



- This function is used to abort an embroidery job in process. This process terminates the entire job.

1. Press the origin (ORG) icon. 

- The following message will prompt, "Terminate embroidery and return to the origin?"

2. Click OK. 

- The frame will move to a center position and the design will reset.

## How to adjust speed

---

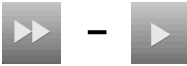

- This function is used to adjust the speed of the stitches incrementally. The number displayed in red is the current speed of the embroidery machine.

1. Press the increments icon. 

2. Press the plus (+) or minus (-) button. 

- If the increments button is displaying one (1) arrow, then the speed can be reduced or increased by 10 stitches per minute.
- If the increments button is displaying two (2) arrows, then the speed can be reduced or increased by 50 stitches per minute.





## How to bring the frame out

---



- This function is used to bring the frame from underneath the needles, so the embroidery is accessible to the user. This function is mostly used when doing appliques.

1. Press the frame offset icon. 
  - The embroidery hoop will move from underneath the needles.
2. Press the frame offset icon. 
  - The embroidery hoop will return the embroidery hoop back into position.

This section intentionally left blank.

# EMBROIDERY HOOP + FLAT FRAME SUPPORT



- The embroidery machine comes with four (4) embroidery hoops and a cap attachment.
- The flat frame support is connected by two (2) screws to the embroidery machine and is resizable in order to adjust to the four (4) different embroidery hoop sizes.
- The embroidery hoops are categorized from A-D with A being the smallest and D being the largest.
- Each embroidery hoop comes with a screw to adjust the sizing on the outer ring, except for the largest embroidery hoop (D), which has two (2) screws on the outer ring.

Embroidery hoops		
Image	Name	Size
	Flat frame support	Adjustable
	Embroidery hoop A	70 by 50 mm
	Embroidery hoop B	110 by 110 mm
	Embroidery hoop C	190 by 140 mm
	Embroidery hoop D	310 by 210 mm



## Flat frame support installation

1. Install the flat frame support by aligning the embroidery frame hole with the dowel on the connecting plate. See Figure 78.

- No. 1 – Flat frame support
- No. 2 – Embroidery frame connecting plate

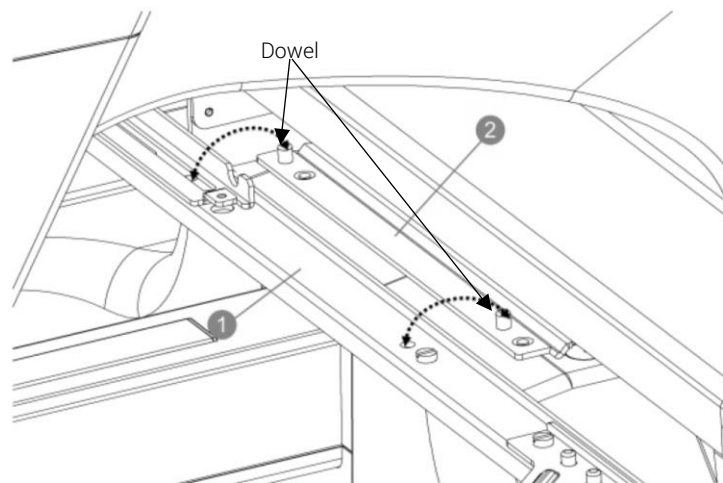

Figure 78

2. Secure the flat frame support to the embroidery frame connecting plate with the two (2) M4x8 screws provided. See Figure 79.

- No. 1 – Screw to secure the flat frame support to the embroidery frame connecting plate
- No. 2. Flat frame support

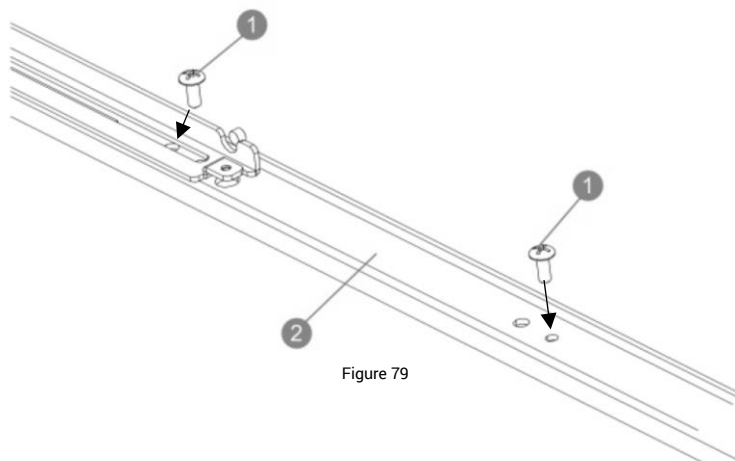

Figure 79

This section intentionally left blank.

## Installing embroidery hoop + adjusting flat frame support



- If the embroidery frame is not correctly installed, the embroidery frame may affect the presser foot, damage the embroidery machine or it can cause personal injury.
- Before frame installation, ensure there is sufficient thread inside of the bobbin.
- The frame is adjusted to fit each frame embroidery hoop individually.
- The left arm of the frame moves right to adjust accordingly.
- Ensure that the flat frame support does not collide with the 10 needle bar rack or any other part of the embroidery machine.

1. Select the embroidery hoop that will be in use.
2. In order to adjust the flat frame support to the frame embroidery hoop, loosen the two (2) screws by turning them counterclockwise. See No. 1 in Figure 80.
  - Do not remove the screws.

Embroidery hoop Adjustments	
Name	Position
Embroidery hoop A	Left arm of embroidery frame moves rightward to the innermost side
Embroidery hoop B	Left arm of embroidery frame moves rightward to the 3 <sup>rd</sup> stuck-point
Embroidery hoop C	Left arm of embroidery frame moves rightward to the 2 <sup>nd</sup> stuck-point
Embroidery hoop D	Left arm of embroidery frame moves to the leftmost side

3. Adjust the width of the flat frame support to the embroidery hoop by pushing it inward or outward. See arrow in Figure 80.
4. Retighten the two (2) screws by turning them clockwise in order to secure the flat frame support.
5. Grab the desired embroidery hoop. See the [Flat frame support](#) section for embroidery hoop details.

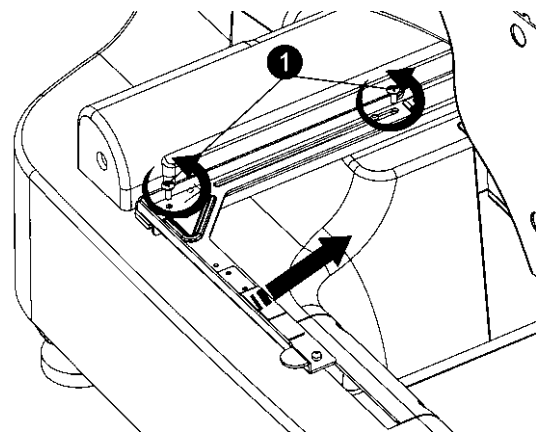

Figure 80

6. Align the left and right side by pushing both sides in simultaneously until the embroidery hoop locks in place. See Figure 81.
7. Insert the frame embroidery hoop into the flat frame support.
8. Click the frame embroidery hoop into the flat frame support.
9. Ensure that the notch of the embroidery hoop connects securely to the pin on the flat frame support.

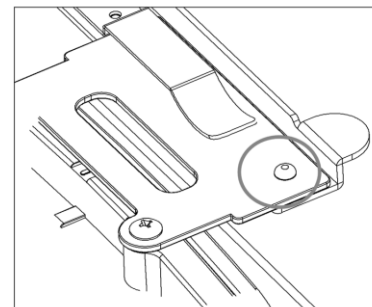
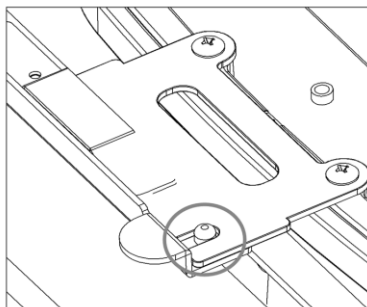

Figure 81

## Framing fabric

1. Place the embroidery hoop on a flat level surface.
2. Loosen the two (2) screws on the flat frame support. See Figure 82.
  - No. 1 and No. 2 screws to be loosened.

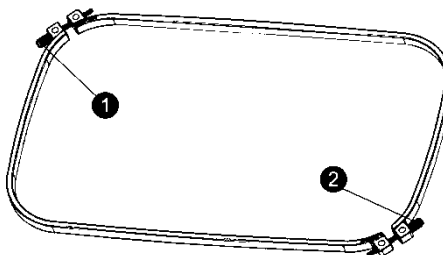

Figure 82

3. Lift and remove internal embroidery hoop. See Figure 83.



Figure 83

4. Place the cloth with its top side up on the external embroidery frame. See Figure 84.

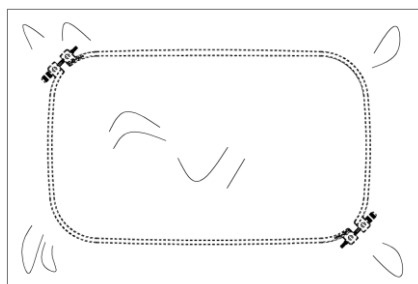
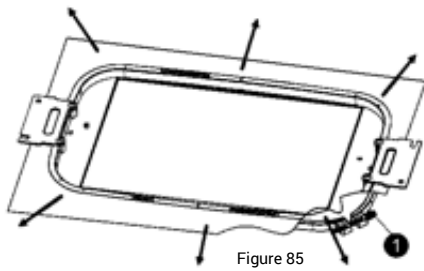

Figure 84

5. Ensure the cloth is stretched out. See Figure 85.



6. Place internal embroidery frame on top of the cloth.
7. Insert internal embroidery frame into external embroidery frame.
  - Internal embroidery frame should be slightly lower than the external embroidery frame.
8. Slightly tighten the two (2) screws and pullout the cloth edges.
9. Finish tightening the two (2) screws.
  - Make sure the cloth is stretched out and tight without any wrinkles.
  - Tap on the cloth and it should make a drum like sound.

This section intentionally left blank.

## Removing the embroidery hoop

---

1. Grab both sides of the flat frame support from the bottom.
2. Push up the frame by using the levers. See No. 1 and No. 2 in Figure 86.
3. Release the frame from the brackets. See No. 3 and No. 4 in Figure 86.
4. Slide the embroidery hoop back towards yourself.

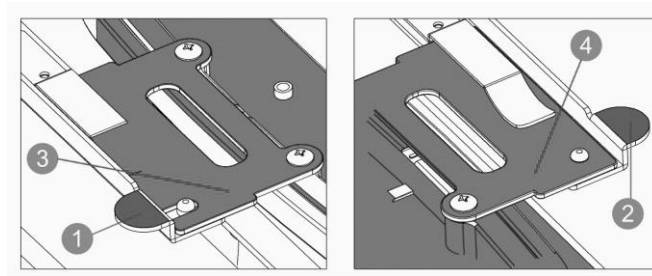

Figure 86

## Removing the flat frame support

---



- Ensure the embroidery machine has stopped running before the flat frame support is removed.
- After the flat frame support is removed, keep the flat frame support away from any part of the embroidery machine.
- To avoid damage, do not raise the flat frame support.

1. Remove the screw on the right side of the support.
2. Remove the screw on the left.
3. Pull the flat frame support up and release.

This section intentionally left blank.

# CAP OVERVIEW

## Cap driver installation

### Tools & Parts:

- 1 cap driver
- 2 4x8 screws
- 1 screwdriver

1. Remove the flat frame support. See the [Removing the flat frame support](#) section.
2. Position the cap driver in-line with the railing (located on the bottom of the sewing arm of your embroidery machine). See Figure 87.
3. Align all four (4) wheels. See Figure 88.

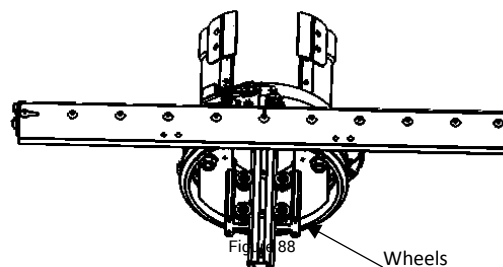
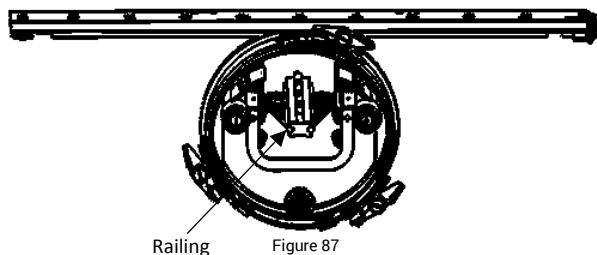

4. Push the cap driver toward the back of the embroidery machine.
5. Align the two (2) sets of holes. See Figure 89.
6. Connect the inner hole of the set of holes with the metal stubs.
7. Match the outer holes of the set of holes. See Figure 89.
8. Insert and tighten each screw.
9. Ensure the cap driver is tightly secured.

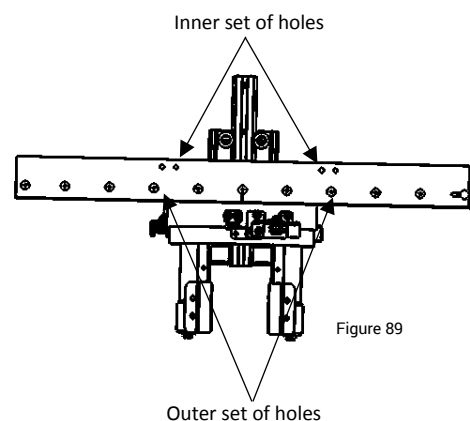

## Cap station installation

---

1. Select a location to clamp your cap station onto.
2. Twist the knob counterclockwise to separate the knob from the cap station device.
3. Ensure enough room is available to fit the width of your desired location.
4. Slide the cap station onto your desired location.
5. Twist the knob clockwise to tighten the grip of the cap station to the desired location.
6. Ensure the cap station is securely attached to the desired location.

 For a more permanent solution, screw the cap station onto a table through the provided holes. To decrease wear and tear, it may be helpful to insert a piece of cardboard or cloth between the clamps and the table's edge.

## Cap embroidery hoop

---

1. Take the cap ring and connect the open metal notch to the center tab on the cap station.
2. Slide and push the cap ring forward.
3. Ensure all three (3) spring locks are connected.
4. Unfasten the flexible metal band and position it to the left of the cap ring.
5. Pull back the sweatband of the cap.
6. Place the backing below the metal tab.
7. Slide in the sweatband between the metal tab and the backing.
8. Ensure extra fabric is out of the way.
9. Position the flexible metal band back over the cap's bill.
  - The flexible metal band is made up of two (2) edges: a smooth edge, closest to the embroidery machine and a serrated edge, closest to you.
10. Place the smooth edge under the metal tab of the cap station.
11. Connect the clasp to the cap ring latch and snap it into place.
12. To remove from the cap station, release the three (3) latches positioned at 1 o'clock, 11 o'clock and 7 o'clock.



## Cap installation

---

1. Rotate the cap 90 degrees to either the left or right.
2. Push forward onto the sewing arm until the cap embroidery hoop ring connects to the cap driver.
3. Rotate the cap back into an upward position with the bill facing upwards.
4. Align the center metal tab on the cap driver with the metal opening of the cap ring.
5. Grab the cap driver from the back.
6. Slide and push the cap ring forward.
7. Ensure all three (3) spring locks are connected.

## Cap embroidery hoop removal

---

1. Release the three (3) latches positioned at 1 o'clock, 11 o'clock and 7 o'clock.
2. Rotate the cap 90 degrees to either the left or right.
3. Slide the cap embroidery hoop away from the embroidery machine.

## Cap driver removal

---

1. Untighten and remove each screw.
2. Disengage the cap driver from its connection to the metal stubs.
3. Slide the cap driver away from the embroidery machine.

This section intentionally left blank.





# TENSION



- Thread color dyes affect the texture of the thread, which can affect how smoothly it slides through the embroidery machine.
- Polyester threads would require nearly twice the amount of tension as rayon.
- Depending on the type of thread, tension knobs will require adjustment. See the
- 
- **Tension** knobs section for more information.
- If you change the weight of the thread, tension will require adjustment.
- Embroidery machine speed may affect tension – the slower the speed, the better the quality.
- Excess dust and lint along the thread path can affect thread tension.

## Check thread tension



- The tension of the bobbin case affects the stitching that comes from every needle bar. Ideally, the bobbin tension setting will produce a one-third (1/3) bobbin thread running exactly down the center of the column, with one-third (1/3) top thread running down each side.
  - User may see bottom thread from the top side of the cloth when top thread tension is too tight.
  - User may see thread circle when the top thread tension is too loose.
  - Under normal use, the user should temporarily stop the embroidery machine and check thread tension after the first 100 stitches of each color.
  - Because of different types or thicknesses of cloth or backing being used, embroidery results may be different from what is expected; ensure to make samples before mass production.
1. Turn your design over to view the backside of the embroidery pattern.
  2. Identify if the bobbin thread is one-third (1/3) of the stitch length.
  3. If the bobbin thread is more or less than one-third (1/3) of the stitch length, adjust the bobbin thread tension. See the **Bobbin tension** section for more information.

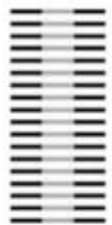

Balanced  
Tension

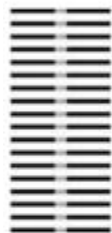

Too Little  
Tension

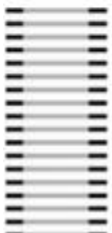

Too Much  
Tension

Figure 90



## Tension knobs

---



- Each design may require different tension settings.
- Experiment by making small quarter (1/4) turns until you feel comfortable with your design.
- You can adjust the tension of your EM-1010 even while it is running.
- To have a great quality design make the following adjustments, if needed.
  - For metallic and polyester threads, turn the tension knob counterclockwise one (1) time.
  - For light color rayon threads, turn the tension knob counterclockwise one to two (1-2) times.
  - For white rayon thread, turn the tension knob counterclockwise one (1-2) times.
  - For medium color rayon threads, turn the tension knob counterclockwise one to two (1-2) times.
  - For dark color rayon threads, turn the tension knob counterclockwise two to three (2-3) times.
  - For black rayon thread, turn the tension knob counterclockwise three (3) times.

### Adjusting thread tension

- Rotate the tension knob clockwise to tighten the tension. See Figure 91.
- Rotate the tension knob counterclockwise to loosen the tension. See Figure 92.

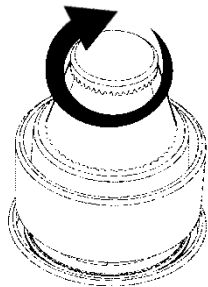

Figure 91

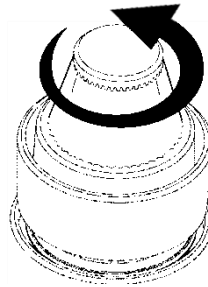

Figure 92

This section intentionally left blank.

## Bobbin tension



- To adjust the bobbin, there is a bobbin tension adjusting screw on the bobbin case. See Figure 94.
- The tension on the bobbin case affects the stitching that comes from each needle bar.
- The most widely accepted tension test: sewing a one-inch (1 in.) tall satin column, then examine the reverse side.
- The bobbin tension setting should be one-third (1/3) bobbin thread running exactly down the center of the column, with one-third (1/3) top thread running down each side.
- The amount of tension required depends on the thread type.
  - Poly threads require nearly twice the amount of tension as rayon threads.
- When stitching onto caps, thick materials or using small lettering, the bobbin tension may need to be tightened slightly.
- Only one-third (1/3) of the bobbin thread should be visible down the middle of the column on the back of the embroidery.
- If a small amount of the bobbin thread is visible, tighten the upper tension knob slightly by turning the knob to the clockwise.
- If a large amount of the bobbin thread is visible, loosen the upper tension slightly by turning the tension knob counterclockwise.
- The top tension knobs will need to be adjusted depending on the thread type and color.
  - For metallic and polyester threads, rotate the top tension knob zero to one (0-1) turns counterclockwise.
  - For light-colored rayon threads, rotate the top tension knob one to two (1-2) turns counterclockwise.
  - For white rayon threads, rotate the top tension knob one (1) turn counterclockwise.
  - For medium-colored rayon threads, rotate the top tension knob one and a half to two and a half (1.5-2.5) turns counterclockwise.
  - For dark-colored rayon thread, rotate the top tension knob two to three (2-3) turns counterclockwise.
  - For black rayon thread, rotate the top tension knob three (3) turns counterclockwise.

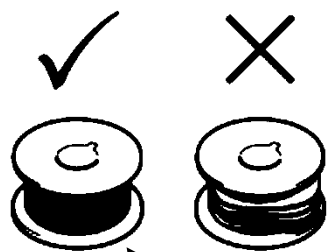

**Note:** Correctly wound bobbin.

Figure 93



ricoma  
THINK BEYOND

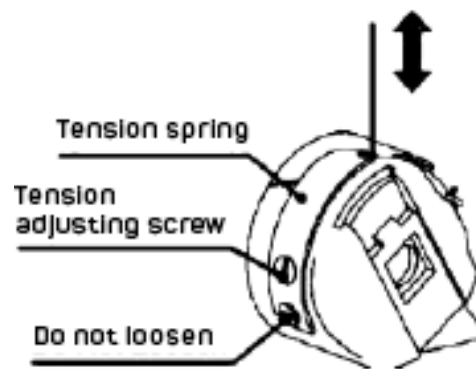

Figure 94

# NEEDLES

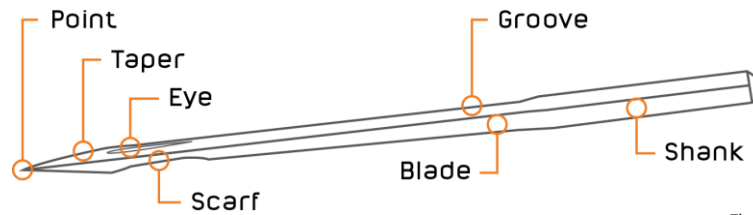

Figure 95

## Anatomy of a needle

- **Shank:** the top part of the needle that goes into the needle bar (into the machine).
- **Shaft/blade:** the part of the needle from the bottom of the shank, down to the top of the needle.
- **Taper:** the part of the needle below the eye.
- **Point:** the part of the needle found opposite to the shank and the first part to penetrate the fabric.
- **Eye:** the area where the thread passes through the needle.
- **Groove/thread groove/front groove:** the groove that runs from the top to the bottom, along the face (front) of the needle.
- **Scarf:** the half-moon cut out on the back of the needle, just above the eye, where the rotary hook passes behind the needle.

## Needle lifetime

Many variables will determine how long a needle will last. The lifetime of a needle depends on which material the needle is made from, point type and the type of material being sewn on.

## When to change a needle

Look for performance changes on your machine such as thread breaks, poor stitch quality, fabric pulls, unusual noises or reduced stitching speed.

## Selecting a needle

---

- Choose the right needle to ensure quality stitches. Embroidering with a needle that is too small or too big for the thread and fabric can result in thread breaks or even skipped stitches. There are three (3) things to consider when choosing the right needle for the job:
  - Finish
  - Size
  - Point
- DBxK5 is an established standard system for an embroidery machine. It is a medium point needle with a larger eye that allows a smoother flow of thread through the eye of the needle. It is slightly less durable due to thinner eye wall. Since the eye of the needle is larger, there are fewer thread breaks. Use ballpoints for stretch materials; use sharps for cotton.
- DBx7ST is ideal for metallic threads. It has an extremely large rectangular eye that allows easy passage of thread.

## Blade size

---

- Choose a finer blade on more fine woven or knitted fabrics and a larger blade for tough fabrics that could cause needle deflection.
- The point must also enter the fabric easily so it does not deflect when it contacts the fabric, which could cause the needle to strike the surrounding metal or inside the hole in the needle plate.
- The two (2) number designation is a combination of the European and Asian size designation numbering systems.
  - The first number, such as 65 or 80 is the European designation and refers to the actual measurement of the blade diameter.
  - The second number, such as 11 or 14, is an Asian numbering system, also formerly used by Singer. In this system, the smaller number indicates a smaller blade diameter.
- **Size 75/11** – Good overall needle. It is used to sew everyday items like golf shirts, sweatshirts, dress shirts, light jackets, lighter canvas, aprons, holiday's stockings, etc.
- **Size 70/10** – Good needle for the newer tech garments. It is used to sew moisture management (wicking), antibacterial, body temp management type garments, especially t-shirts and golf shirts.
- **Size 65/9 or 60/8** – Good needles for very light/delicate materials. They are used to sew silks or fine linens. Also, used to get the stitches closer together, such as when you might sew extremely detailed designs like a detailed patch or small lettering.
- **Size 80/12** – Good needle for heavier materials. Used to sew heavy canvases, vinyl, lighter leathers, ball caps, visors, etc.
- **Size 90/14** – Good needle for metallic thread. It has a larger eye. Used to sew canvases and belts, since it is a very stiff needle.

## Needle finishes

- Most sewing and embroidery needles have a chromium plating to enhance durability and appearance.
- Titanium coated needles are more expensive than chromium-plated needles, but they can last as much as five (5) to seven (7) times longer than chromium-plated counterparts. They also reduce friction on the thread, which could save time, labor and reduce the frequency of thread breaks.
- Titanium needles are a golden color and are available in popular sizes.

## Needle + thread matrix

Refer to the chart below to view the application range of threads and needles used for general embroidery.

Size of a needle			Size of a thread			
U.S.A	Japan	Germany	Cotton	Silk	Nylon	Rayon
0.25	9	65	70 – 80	100 – 120	130 – 150	70 – 100
0.27	10	70				
0.29	11	75	50 – 60	80 – 100	100 – 130	100 – 130
0.32	12	80				
0.34	13	85	50 – 60	60 – 70	80 – 100	130 – 150
0.36	14	90				

This section intentionally left blank.



## Point types

- Different point types are necessary to avoid damaging and to penetrate cleanly on a variety of fabric types.
- Always use the smallest possible needle in order to create the smallest hole.
- Heavy materials cause the needle to bend, or deflect, which causes needle breaks, thread breaks, missed stitches and more. Control needle deflection by slowing the speed of the machine down and/or changing the size of the needle.

### Acute round point

- Used primarily on woven fabrics.
- Sharp point needle (SPI).

**SPI Acute round**



**R Normal round (Sharp)**



**SES Light ball point**



**SUK Med ball point**



Figure 96

### Slender sharp point

- Used to penetrate high thread count fabrics, microfibers and certain synthetics
- Normal round point (R).

### Normal sharp point

- Used for woven fabrics, including finished caps.

### Light ballpoint

- Designed to spread yarn in knitted fabrics rather than piercing them to maintain the structural integrity of the knit. This is the most popular needle type and is considered a universal point type, suitable for most knit and woven fabrics.
- Light ballpoint (SES).

### Medium ballpoint

- Designed to spread heavy yarns such as those used in heavy knitted fabrics.
- Two (2) primary point types used for sewing and embroidering: sharp point and light ballpoint.
- Medium ballpoint (SUK).

## Needle replacement



- Discard old needles in a sharp-safe container.
- A basic guideline that many professional embroiderers use to determine when to change needles is the “three strikes” rule. When there have been three (3) consecutive thread breaks on a needle, it should be changed.
- The scarf of the needle must face the BACK of the machine. If the needle is not positioned correctly, the machine will not work properly.



Figure 97

1. Shut down the embroidery machine.
2. Remove the needle excess.



If broken needle pieces are not on the garment, look in the bobbin area.

3. Loosen the screw.
4. Release the needle.
5. Insert a new needle. See No. 1 in Figure 99.
6. Ensure the big groove and the needle scarf faces completely forward. See Figure 98.
7. Tighten the screw. See No. 2 in Figure 99.

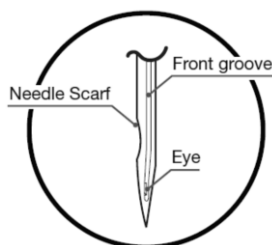

Figure 98

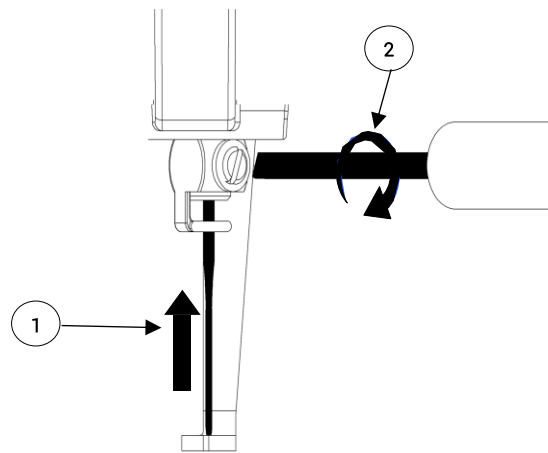

Figure 99



# COMPLETING A FLAT DESIGN (START TO FINISH)

## Prepare

1. Select the desired embroidery hoop. See the [Embroidery hoop specifications](#) section.
2. Place the fabric with backing onto the embroidery hoop. See the [Framing fabric](#) section.
3. Install the flat frame support. See the [Flat frame support installation](#) section.
4. Insert the USB into the USB port on the right side of the panel. See the [Importing/uploading a design](#) section.
5. Ensure the embroidery status is set to unlocked. See the [Embroidery status](#) section.

## Embroider

6. Click on the file icon. 
7. Select your design.
8. Press the EM-1010 icon alongside the blue arrow to import the design into the embroidery

machine's memory.

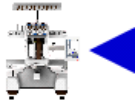

9. Now select the EM-1010 icon on the top row. 
10. The last imported design will be the last one in the list. Select the desired design.

11. Press OK. 

12. Click on the design set button. 

13. Select the embroidery hoop selection icon on the bottom right. 

14. Select the preset embroidery hoop size.

15. Press OK. 

16. Press escape. 

17. Press the color sequence setting icon. 

18. Choose the colors of your design.

19. Press OK. 

20. Trace your design to make sure that it fits within the embroidery hoop and to check its

placement. See the [Embroidery design trace](#) section.



21. Press start to begin embroidering your design.





# COMPLETING A CAPS DESIGN (START TO FINISH)

## Prepare

1. Install the cap driver. See the [Cap driver installation](#) section.
2. Set the cap and the backing on the cap embroidery hoop, on the cap station. See the [Cap embroidery hoop](#) section.
3. Grab the extra fabric near the back of the cap and secure it with the supplied binder clips, making sure the binder clips are facing inward. See the [Framing fabric](#) section.
4. Insert the cap embroidery hoop onto the cap driver. See the [Cap installation](#) section.
5. Insert the USB into the USB port on the right side of the panel. See the [Importing/uploading a design](#) section.
6. Ensure the embroidery status setting is set to unlocked. See the [Embroidery status](#) section.

## Embroider

7. Click on the file icon. 
8. Select your design.
9. Press the EM-1010 icon alongside the blue arrow to import the design into the machine's memory. 

10. Now select the EM-1010 icon on the top row. 
11. The last imported design will be the last one in the list. Select the desired design.

12. Press OK. 

13. Click on the design set button. 

14. Select the embroidery hoop selection icon on the bottom right. 

15. Select the preset cap embroidery hoop size.

16. Press OK. 

17. Press escape (to go back to the main panel). 

18. Press the color sequence setting icon. 

19. Choose the colors of your design.

20. Press OK. 

21. Trace your design to make sure that it fits within the hoop and to check its placement. See the [Embroidery design trace](#) section. 

22. Press start to begin embroidering your design. 

# MAINTENANCE + CARE



- This is the most important maintenance that needs to be completed.
- Repeat the following process every day before using your embroidery machine to ensure the embroidery machine runs smoothly.
- Wipe down the outer surface with a soft cloth and clean the bobbin with the toolkit brush.
- Use sewing machine oil ONLY for lubrication points (included in the toolbox).
- White lithium grease can be found at any hardware store. It does not come in your toolbox.

## Rotary hook



- Apply lubrication oil to the rotary hook every three (3) to four (4) hours when in constant use but first turn off the embroidery machine and unplug it from the electrical outlet.

1. Follow the steps in the [Bobbin removal](#) section.
2. Add two to three drops of embroidery machine oil to the rotary hook.
3. Follow the steps in the [Placing the bobbin case into the rotary hook](#) section.

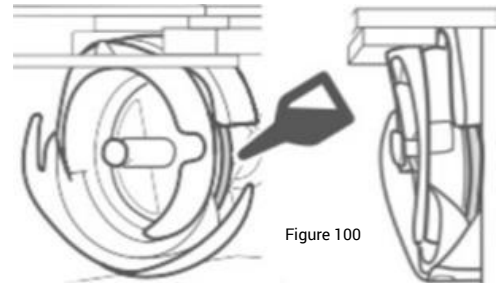

## Machine head



Figure 101

- Use white lithium grease every five (5) months
  - on the metal wheels
  - on the bottom metal bar (both are located behind the machine's head)
- Repeat the process on each side of the machine's head manually, using the manual needle switch display icon on your panel to needle #1, then to needle #10.
  - Needle switch display icon 

## Level arms



- Apply lubrication oil to the level arms every week of continuous use.

Figure 102

## Head rail

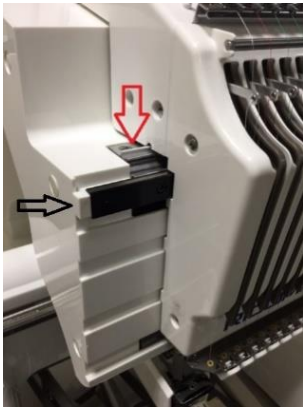

Figure 103

- #1 – Apply two (2) or three (3) drops of sewing machine oil to the metal rail (top arrow) every week. Repeat the process on each side of the machine’s head manually, using the manual needle switch display icon on your panel to needle #1, then to needle #10.

- Needle switch display icon



- #2 – Add grease every five (5) months (black arrow) on the black metal bar. Repeat the process on each side of the machine’s head manually, using the manual needle switch display icon on your panel to needle #1, then to needle #10.

## Bobbin case maintenance

- Clean the accumulated lint from underneath the tension plate with the corner of a business card or remove it with the bobbin thread itself – like dental floss.

⚠ Resist the temptation to blow the lint off the case – this deposits damaging saliva onto your bobbin case. You may use an air gun to blow/remove the lint from the bobbin case.

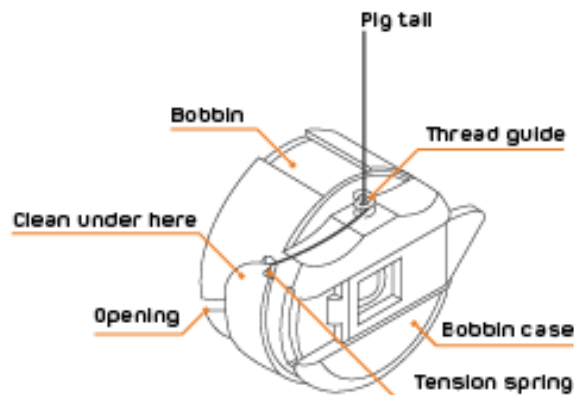

Figure 104



---

# TROUBLESHOOTING

## Thread break

---

- If thread breaks occur on just some of the needles, check for defective needles or needles not inserted properly.
- If thread breaks are occurring frequently on all the sewing head's needles, then hook timing needs to be corrected.
- Check the thread path to make sure it is following the correct path from the thread cone to the needle. See Figure 42.
  - Incorrect thread tensions will give you thread breaks.
    - Tight tension could lead to missed stitches, thread breaks, pulling, puckering and thread stress.
    - Loose tension causes the thread to pile up and loop.
- Inspect the needle position and determine if an actual thread break has occurred.
  - If no thread break is apparent:
    - Check all the thread paths.
    - Perform a manual trim.
    - Check the bobbin supply.
    - Ensure the bobbin is installed properly.
    - Remove any lint or dirt build-up in the bobbin case.
    - Make sure the thread trimmer knife is fully retracted.
  - If a thread has broken:
    - Follow the correct thread path.
    - Thread the needle.

## Reasons

### Defective thread

- Pull thread until the defective part has passed.
  - If that does not work, try replacing the thread with a new cone.

### Garment or fabric

- If the fabric is too thick, needles tend to bend slightly as they pass through, causing the thread to scrape against the needle plate, resulting in the thread shredding. To fix this problem, try a larger needle.
- Hidden obstructions in the garment: bulky seams, inside pockets, hidden buttons.
- Ensure the embroidery hoop is framed properly. Loosely framed fabric will bounce up and down during sewing. See the [Framing fabric](#) section.
- Excessive backing will apply greater friction to the thread and needle and cause thread or needle breaks.

### Embroidery design

- Too high density of thread in the design can cause needle deflection, which leads to thread shredding and breaks. Too many stitches in a small area can cause thread breaks. Try deleting short stitches or increasing the design by five (5) to ten (10) percent.
- Extremely short stitch lengths may cause the thread to pile up in one area. Known as nesting, this issue causes thread to shred and break.

## Prevention

- To prevent thread breaks, store threads properly in a dark, cool place.
- Old threads not stored properly will cause thread breaks.
- Prolonged exposure to air, light, age and heat will make threads become brittle.
- Do NOT use tape to tie off thread ends, since tape leaves a stick residue that causes friction and breaks.
- Check for burrs in the thread guides, needle eye, thread plate and hook.

## Needle break

---

- Changing a needle is one of the simplest types of troubleshooting. Set the needle aside while you determine whether a fresh needle corrects the problem. If you determine that the needle was the likely cause of the problem, discard in an old medicine bottle or another sharp-safe container.
- After three consecutive thread breaks on a needle, the needle should be changed

Check the following common reasons to see why your needle(s) may be breaking.

- Needle is worn out or old
- Designs with too many stitches
- Hitting the embroidery hoop
- Fabric moving while needle is penetrating

## Bobbin tension

---

If you suspect that the bobbin is not rotating smoothly in the embroidery machine, try the following.

1. Place the bobbin case with the bobbin face down, flat on a flat surface.
2. Pull a few inches of the thread out.
  - If the bobbin is not spinning freely, the odds are that it is not spinning freely in the embroidery machine either.
3. Retest the case with another bobbin.

This section intentionally left blank.



## Timing overview

---

Adjusting the timing of a needle and hook

- The timing of the needle is set up at 195 degrees and the relation between the needle and the hook is as follows.
  - If the space between the needle and the hook point is out of range, as shown in Figure 105, the thread will not catch, causing thread breaks, and if too close, causing broken needles.

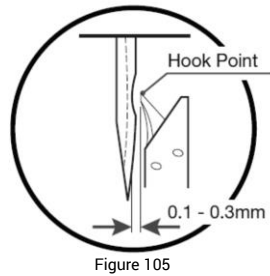

Figure 105

- The space of the needle and the hook of 0.1 ~ 0.3 mm is proper. See Figure 106 for example.

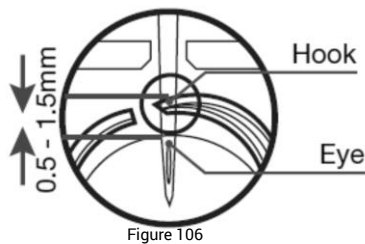

Figure 106

This section intentionally left blank.

# ERROR MESSAGES

## Thread break (“T-break”)



- If a thread break occurs, the embroidery machine will stop automatically. If you need instructions on how to thread the needle, see the [Threading a needle](#) section.

1. Identify the thread break by locating the “T-break” icon on the panel.
2. Click on the “T-break” icon to display the stitch float mode icon.
3. Back up your design to the desired stitch.
4. Press the float mode key three (3) times until the stitch icon appears.
5. Thread the needle.

6. Press start. 

## Needle break



- Replace damaged or bent needles.
- Make sure to thread the needle from the front to the back and down the presser foot. If you need instructions on how to thread the needle, see the [Threading a needle](#) section.
- Needles break for different reasons.
  - The most common reasons are:
    - A worn out or old needle.
    - Designs with too many stitches and/or are high density for the design area.
    - Smoothing is blocking the stitch path.
    - Hitting the embroidery hoop is occurring.
    - The fabric moving while the needle is penetrating.

1. Remove the needle break excess.
  - A tweezer might be a useful tool to remove the remaining pieces.
2. Take a screwdriver and loosen up the screw specific to the needle.
3. Remove the released needle.
4. Insert a new needle.
  - Ensure the big groove and the needle hole facing completely forward.
5. Tighten the screw.
6. Thread the missing path.
  - Make sure to thread the needle from the front to the back and down the presser foot.

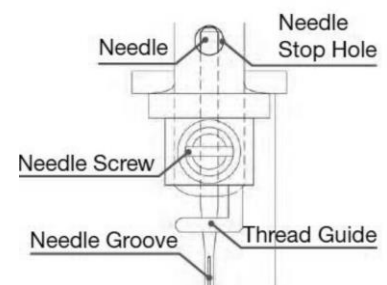



Figure 107





## Main axis not at 100 degrees

When your main access is not at 100 degrees, an error message will be displayed on your screen.

1. Click OK. 

2. Press the 100-degree button. 

If you are still receiving the error message,

1. Clear the message from the screen.

2. Turn off the embroidery machine.

3. Rotate the degree knob in the back of the embroidery machine to 100 degrees. See Figure 108.

4. Press the 100-degree button. 

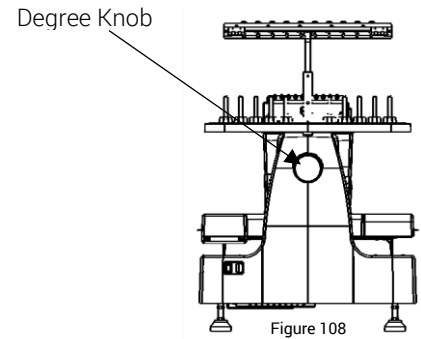

**NOTE:** If you are still experiencing issues, please contact your local dealer where you made your initial purchase.

This section intentionally left blank.

## QUICK REFERENCE GUIDE / CHECKLIST



Before embroidery machine operation, please confirm the following steps have been performed.

	Step	Operation	Reference Page
<input type="checkbox"/>	1	Important: Before getting started	12
<input type="checkbox"/>	2	Threading top thread	37
<input type="checkbox"/>	3	Check thread tension	81
<input type="checkbox"/>	4	Bobbin installation	32
<input type="checkbox"/>	5	Turning on	53
<input type="checkbox"/>	6	Input design	61
<input type="checkbox"/>	7	Select embroidery design	62
<input type="checkbox"/>	8	Select embroidery hoop	62
<input type="checkbox"/>	9	Put cloth in embroidery hoop	75
<input type="checkbox"/>	10	Install embroidery hoop onto the embroidery machine	74
<input type="checkbox"/>	11	Check embroidery area	68
<input type="checkbox"/>	12	Start embroidery	60
<input type="checkbox"/>	13	Remove embroidery hoop and cloth	77
<input type="checkbox"/>	14	Turning off	53